



G17	AR40.10-P-1025-01A	Eliminating radial runout		
------------	--------------------	---------------------------	--	--

The radial runout on the tire may measure max. 1.0 mm. On sheet-steel disc wheels it may be possible to obtain better relative positioning of the tire to the wheel by turning the tire, but only if there are definitely no standing or braking flatspots.

When driving, flatspots are characterized by vibrations or knocking tire rolling noises, and can be eliminated as follows:

- 1 Inflate wheels to a tire pressure of 4 bar and lay (do not stand) them in a paint drying box for four hours at approx. 80°C).
- 2 Allow wheels to cool, correct tire pressure, balance wheel statically and match if necessary.

**H17**

AR40.10-P-1010-01A

Checking condition of disc wheel

- 1 Check the inside and outside of wheel for dirt; clean wheel if necessary.
- 2 Check contact surface of disc wheel for contamination, clean if necessary.
- 3 Check centering and spherical caps as well as rim flanges of disc wheel for damage. The spherical caps must be free of grease.

Light-alloy disc wheels

- 4 The rear flanges of the light-alloy disc wheel can exhibit increased wear under the following conditions:
High load, trailer operation, insufficient tire inflation, use of non-recommended tire makes or designs, accumulation of dirt, sand and thawing salt.
- 5 The wear may be a maximum of 1 mm.

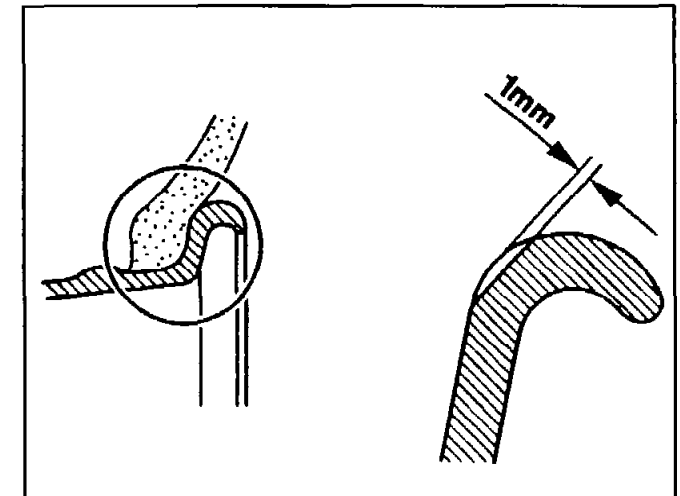

P40.10-0259-01



J17	AR40.10-P-1040-01A	Mounting centering sleeve	
------------	--------------------	---------------------------	--

Commercially available tools (refer to Workshop Equipment Manual)

Number	Designation	Company (e.g.)	Order number
WH58.30-Z-1003-18A	Centering sleeve DUO-FLEX 2 When ordering, specify flange shaft diameter and model of balancing machine	HAWEKA D-30928 Burgwedel	16 100 8006
WH58.30-Z-1004-18A	Conversion kit	Hofmann D-64319 Pfungstadt	6416 451

- 1 A centering sleeve (arrow) must be used on balancing machines approved by Mercedes-Benz due to the segment centering of the disc wheels.
- 2 The disc wheel is supported considerably better on the balancing machine due to the centering sleeve and thus balancing errors are avoided.

HAWEKA centering sleeve

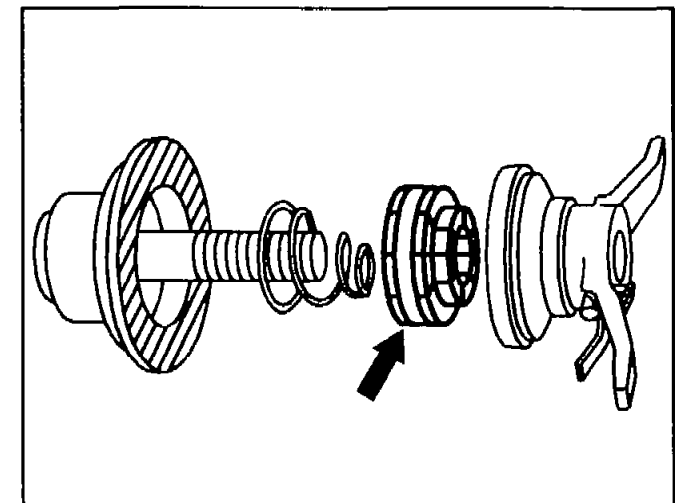



Hofmann centering sleeve

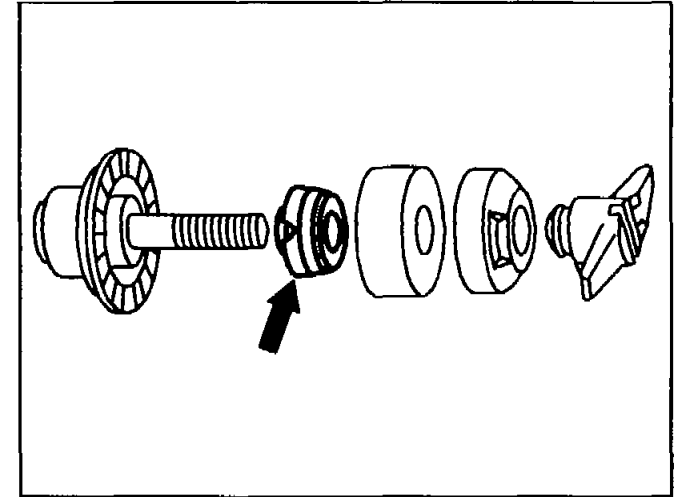

P40.10-0213-01

L17 AR40.10-P-1040-04A	Adjustment value on the balancing machine for special protection vehicles with CTS wheels		
-------------------------------	--	--	--

The following adjustment values are to be set on the balancing machines when balancing CTS wheels:

- 1 Rim width 180 mm = 7 J
 Rim diameter 458 mm = 19"
 Distance dimension distance between the balancing machine and the circumferential rebate for the balance weight

- 2 The trim frame (43f) must be detached before installing the balance weight on the outside of the wheel.

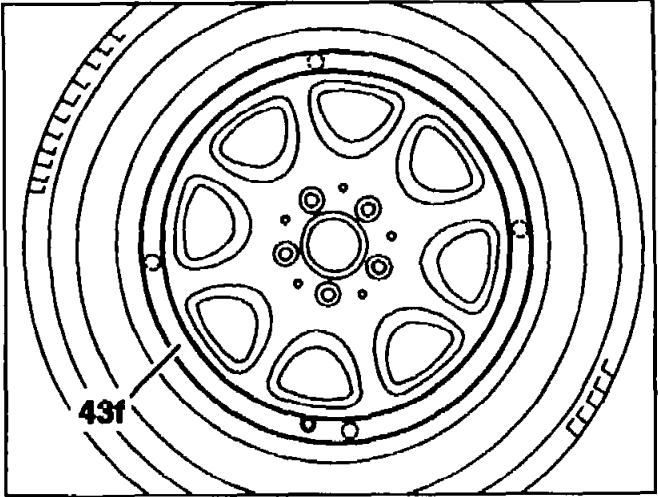

P40.10-0208-01

M17

AR40.10-P-1040-02A

Balancing on vehicles with 4MATIC**Front axle**

- 1 Raise vehicle at the front axle and support control arms with measuring trestles.
- 2 Raise vehicle at the rear axle and support at the sides with trestles.
- 3 Drive the front wheels with the engine (120-140 km/h).

Rear axle

- 1 Raise vehicle at the front axle and support with trestles.
- 2 Raise vehicle at the rear axle and support spring links with measuring trestles.
- 3 Drive the rear wheels with the engine (120-140 km/h).

 If the front axle is not raised, switch off the 4MATIC system by moving the service valve (test position A) or by moving the changeover switch to the "Test" position.

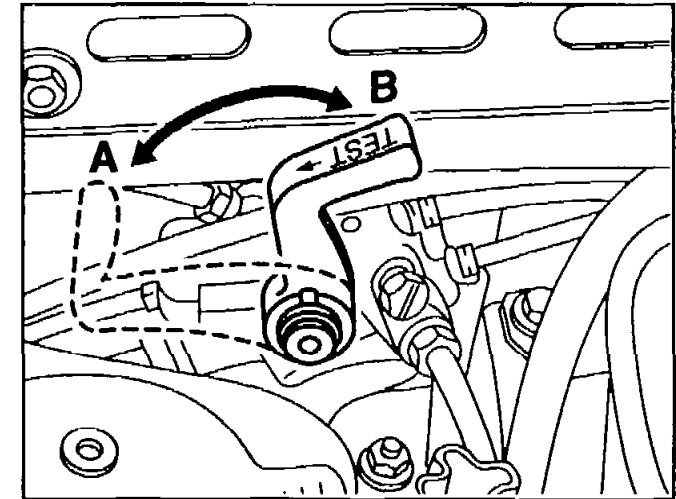

P40.10-0210-01

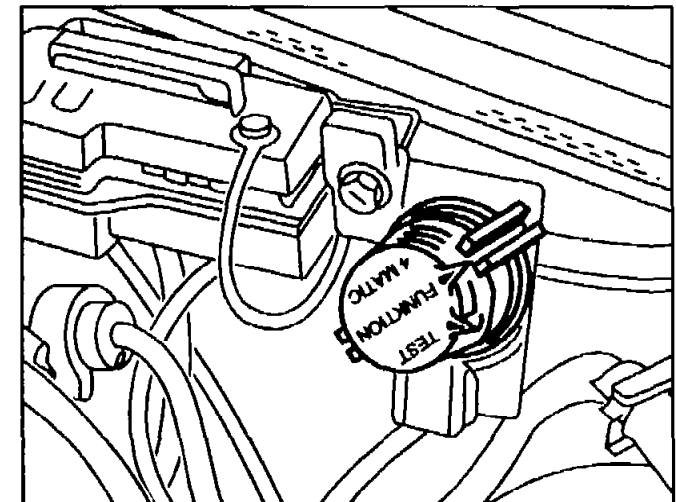

P40.10-0211-01



N17	AR40.10-P-1040-03A	Balancing on vehicles with ETS, ASR or ESP	 140 589 14 63 00 Adapter	
------------	--------------------	--	--	--

Balancing the rear wheels on models 124 and 129 without module box

- 1 Ignition **OFF**.
- 2 Disconnect plug from ASR control unit or relay of hydraulic unit.
- 3 Support rear axle spring links on measuring trestles.
- 4 Drive the rear wheels with the engine (approx. 120-140 km/h).
- 5 After balancing, ignition **OFF**.
- 6 Connect plug of ASR control unit or relay of hydraulic unit.



Balancing the rear wheels on models 124 and 129 with module box, and models 140, 170, 202, 210

- 1 Ignition **OFF**.
- 2 Connect pulse counter adapter (075) 140 589 14 63 00 in test coupling X11/4.
- 3 Attach bridge between sockets 6 and 1.

i The control unit is now switched off and the warning lamp in the instrument cluster lights up.

- 4 Support rear axle spring links on measuring trestles.
- 5 Drive the rear wheels with the engine (approx. 120-140 km/h).
- 6 After balancing, ignition **OFF**.
- 7 Disconnect pulse counter adapter (075).



On model 129 a fault is stored in the soft top control unit due to the speed signal from the rear axle when the vehicle is raised.
Erase the fault code after balancing.

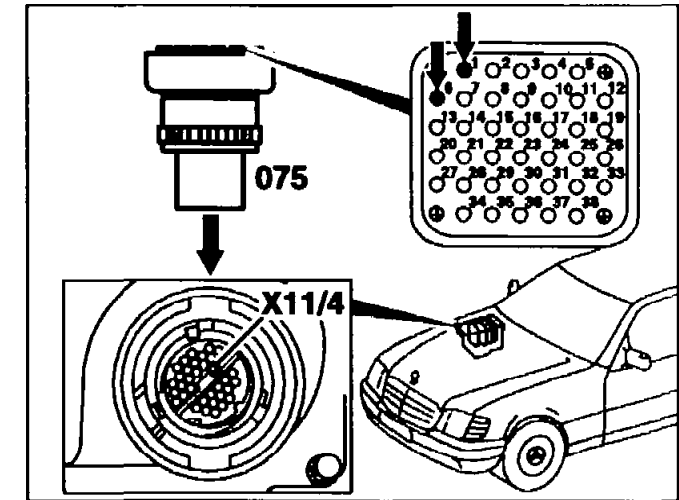

P40.10-0209-01