

## 72-260 Functional description tailgate lock with electromechanical closing assist (T-sedan)

### Technical revisions tailgate lock model 124 T-sedan

Designation	Type and reason for revisions	Installation data
Plug connection Microswitch tailgate lock (A 12/s1s2x)	Plug connection for easier replacing of microswitches (A 12s1, A 12s2)	approx. 06/86

#### A. General

The tailgate is provided with an electromechanical closing assist as standard equipment. After pushing slightly against tailgate (initial detent position), an electric motor is activated by way of a microswitch (A 12s1) integrated in lock mechanism, and will pull the rotary latch into the main detent, by way of a gear unit. The closing power amounts to max. 1200 N. The electric motor is switched off by a microswitch located in a lateral gear unit (1) adjacent to an electronic timer and activated by the propeller shaft. When the tailgate is prevented from perfect closing (main detent) by an object, the motor will be switched off by the electronic timer after approx. 10 s. Perfect closing of tailgate is indicated with the switch actuated (S 18/1, position II) of the rear interior lights, and with microswitch (A 12s2) opened by extinction of the interior lights.

When the supply voltage or the closing assist are inoperative, the tailgate can also be closed mechanically.

The tailgate lock is available in the versions with or without central locking system, each time with safety lock for children.

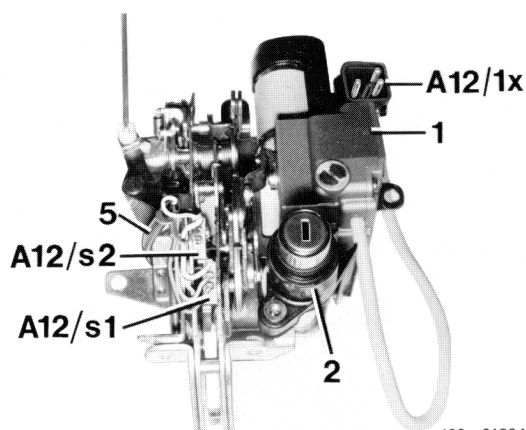

182 - 31884/1

USA version with central locking system only,  
without safety lock for children.

## **B. Operation**

Operation of tailgate is described in microfilm  
Central locking system, model 124.