

42-0220 Checking, removal and installation of brake disc on front axle

Preceding work:
 Remove, mount wheels (40-0015).
 Checking and replacing brake pads (42-0160)

Operation no. of operation texts and work units or standard texts
 and flat rates
 42-2777, 42-2782

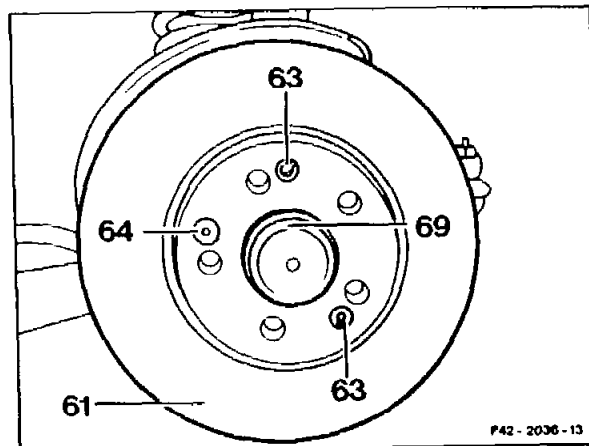
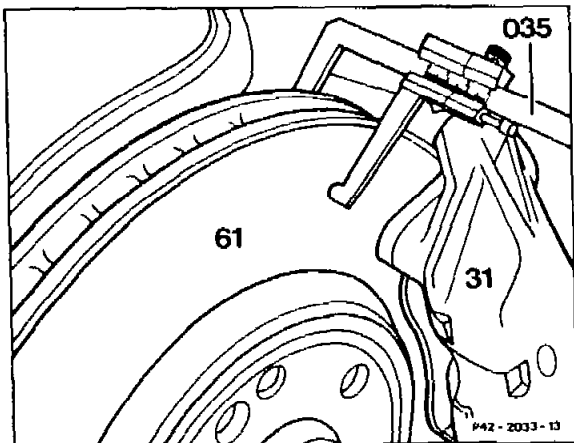

(Brake disc 61)

a) Check wear between guard and brake caliper, or with brake pads removed, in lining opening with vernier gauge (035) 140 589 00 19 00 (see Data).

b) Inspect visually

It is not necessary to replace ventilated brake discs (61) with hairline cracks up to 25 mm in length, which may occur due to high stress. Replace brake discs (61) with gaping cracks, with scoremarks deeper than 0.5 mm or when the wear limit is reached.

Brake caliper (31)

remove, install (42-0100 or 42-0110).
 Fasten brake caliper (31) in wheelhouse with a suitable hook.



Do not subject brake hose to tension.

Retaining bolt (64)	Screw out. Replace. Tightening torque 10 Nm. Torque wrench 001 589 72 21 00.
Brake disc (61)	remove from wheel hub (69). When installing, both roll pins (63) must sit properly in the brake disc chamber. Observe installation note for brake discs.
Guard	check attachment to steering knuckle.
Axial wheel bearing play	check and adjust (33-0300), see testing note on axial wheel bearing play.



Data

Model	Brake disc thickness	Limit dimension for maintenance service	Wear limit	Brake disc dia.	Max. lateral runout
124.003 ²⁾ 124.004 ²⁾ 124.020 124.021 124.023 ²⁾ 124.041 124.043 ²⁾ 124.080 124.081 124.083 ²⁾ 124.10 ⁵⁾ 124.120 124.125 124.126 124.130 124.180 124.185 124.186 124.190	12	10.5	10	284 ± 0.4	0.12
124.003 ³⁾ 124.004 ³⁾ 124.007 124.019 124.022 124.023 ³⁾ 124.026 124.027 124.028 124.030 124.040 124.042 124.043 ³⁾ 124.050 124.060 124.062 124.079 124.082 124.083 ³⁾ 124.088 124.090 124.10 ⁷⁾ 124.127 124.128 124.129 124.131 124.133 124.188 124.191 124.193 124.2 ¹⁾ 124.3 ¹⁾	22	20	19.4	284 ± 0.4	0.12
124.008 ⁸⁾ 124.029 ⁸⁾ 124.031 124.032 ⁸⁾ 124.034 ⁴⁾ 124.051 124.052 ⁸⁾ 124.061 124.091 124.092 ⁸⁾	22	20	19.4	295-0.4	0.12
201.018 201.022 201.023 201.024 201.122 201.126	11	9.5	9	262 ± 0.4	0.12
201.028 201.029 201.034 201.035 201.128	22	20	19.4	262 ± 0.4	0.12
124.036 ⁶⁾ 201.036	28	26	25.4	300 ± 0.4	0.12
124.008 ¹⁰⁾ 124.029 ¹⁰⁾ 124.032 ¹⁰⁾ 124.034 ¹¹⁾ 124.052 ¹⁰⁾ 124.066 124.092 ¹⁰⁾	25	23	22.4	294 ± 0.4	0.12
124.034 ¹²⁾ 124.036 ⁸⁾	30	28.5	28	320 ± 0.4	0.08

1) Brake discs with modified ventilation and brake disc drum with bores (4MATIC only).

2) Up to 06/88.

3) As of 07/88.

4) (J) (USA) model year 92.

5) Up to 09/90.

6) Up to 01/93.

7) As of 10/90.

8) As of 02/93.

9) Up to 10/92.

10) As of 11/92.

11) Fitted up to 02/93, (J) (USA) as of model year 93.

12) Fitted as of 03/93, except (J) (USA).

Installation note, brake disc

Before installing brake disc remove any rust present on brake disc flange and on front wheel hub (69). Lightly coat fitted seat of front wheel flange with heat-resistant permanent lubricant (Molykote paste "D", Molykote paste G Rapid, Liqui-Moly paste 36).

Replacement brake discs are coated with lacquer to protect against corrosion. This protective lacquer (grey varnish) is automatically rubbed off during the first braking maneuvers. The effectiveness of the brakes is not impaired. The following detrimental effects may occur briefly:

- Grating noises during the first braking maneuvers
- Squealing of the unactuated parking brake when the vehicle is moving
- Smell from the brakes during the first severe braking

These disturbances disappear again after a few braking maneuvers (e.g. in the course of the usual brake test on a brake dynamometer which follows replacement of the brake discs).

Do not confuse ventilated brake discs and solid brake discs (when the brake linings wear, the piston extends too far or the brake lining fall through between the disc and brake caliper). Always replace brake discs as pairs only.

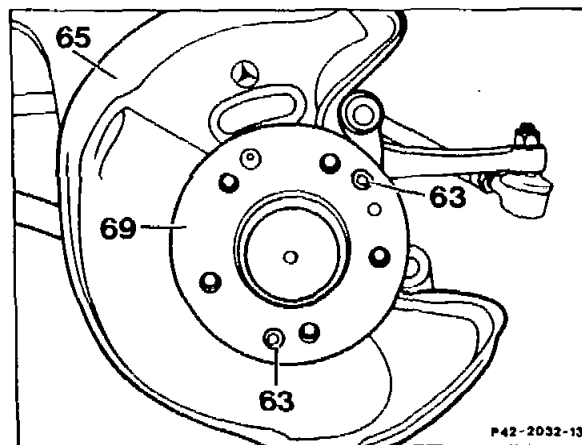

63	Roll pin
65	Cover
69	Front wheel hub



On model 124.036 as of 02/93 (not , the brake discs are combined with the direction of rotation (curved arrangement of webs for ventilation openings).

Identification

- Letter "R" (for right) or "L" (for left) on chamber of the brake disc in the area of the part no.
- Groove on circumference of inner brake ring of the **right-hand** brake disc.

Testing note on axial wheel bearing play

If the pedal travel varies during the test drive (primarily after cornering), check the axial wheel bearing play of the front wheel hubs (33-300). Measure lateral runout of brake disc at outer circumference. For this purpose use dial gauge holder (033) 363 589 02 21 00 and dial gauge A1 DIN 878 (032). If the lateral runout is > 0.12 mm, replace **both** brake discs.

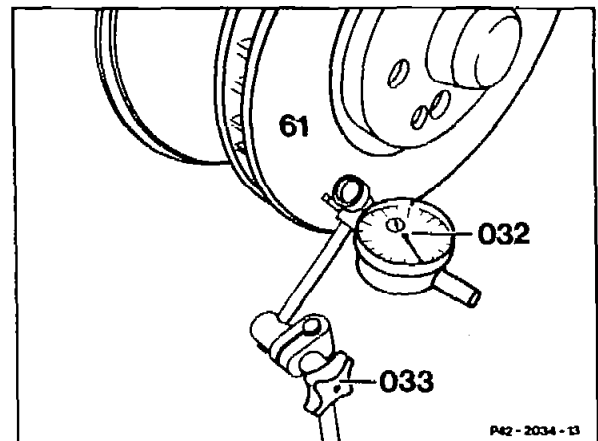

- 61 Brake disc
- 032 Dial gauge
- 033 Dial gauge holder

Special tools

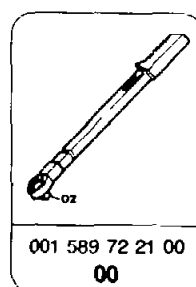
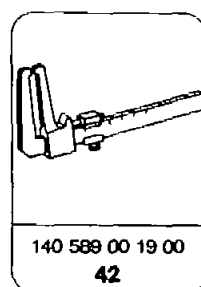
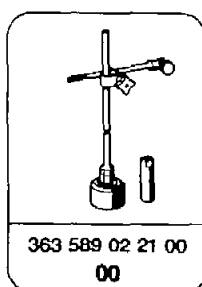

Commercially available tools and testers

Designation

e.g. Messrs., order no.

Dial gauge A 1 DIN 878

Mahr, D-73734 Esslingen
Order no. 311 000