

## 42-0100 Removal and installation of fixed caliper on front axle

Preceding work:  
Lift vehicle on lifting platform (00-0908).  
Remove front wheels (40-0015).

Operation no. of operation texts and work units or standard texts and flat rates.  
42-5131, 42-5134

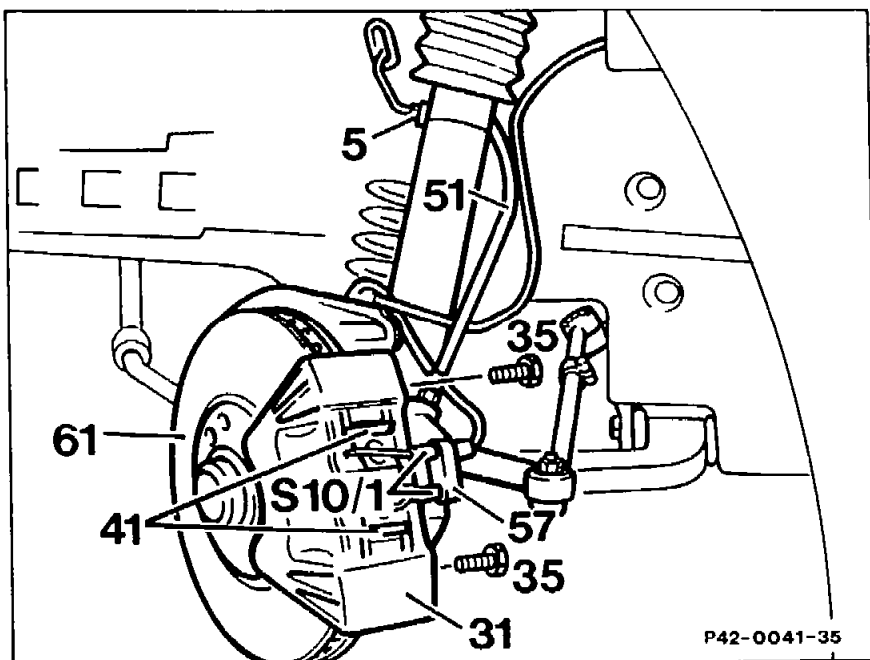

**Models 124.008/029/031/032/034/036/051/052/061/066/091/092, 201.036**



Do not completely drain brake fluid supply reservoir to prevent air from getting into the brake system. If drained completely, it is necessary to bleed the entire brake system (special bleeding procedure required for vehicles with ASR).

Brake hose (51) .....

first unscrew at brake line (5) using open double box wrench 9 × 11, then loosen and remove brake hose (51) from cylinder housing. Seal off connections immediately with blind plugs. Pay attention to correct positioning when installing, see installation note.

	Tightening torques: Brake line (5) to brake hose (51) 14 Nm, brake hose to brake caliper 18 Nm or 9–13 Nm on model 124.036 up to 01/93 and model 201.036 Evolution II with "Brembo" caliper). Open box wrench (14 mm) 000 589 76 03 00, torque wrench 000 589 72 21 00.
Left front brake pads wear sensor (S10/1) . . . . .	disconnect at plug connection (57), connect. Check and replace if required.
Plug connection (57) . . . . .	disconnect from fixed caliper (31).
<b>ABS vehicles</b>	
Speed sensor . . . . .	screw off, screw on
Self-locking bolts (35) . . . . .	screw out of steering knuckle. <b>Replace.</b> Tightening torque 115 Nm (180 Nm on model 140). If new self-locking bolts are extremely hard to screw in, chase threads in steering knuckle with M 12×1.5 tap to remove glue residues from micro-encapsulated bolts. Torque wrench 001 589 67 21 00.
Fixed caliper (31) . . . . .	remove from steering knuckle. It is not necessary to disconnect the brake hose (51) for axle repairs. Screw fixed caliper (31) off steering knuckle and fasten in wheelhouse with suitable hook. Observe Note on fixed calipers!
	 Do not subject brake hose to tension. Reinstall in opposite order.
Front wheel brake circuit . . . . .	bleed (42-0010).
	 Observe disposal regulations for brake fluid!
Brake system . . . . .	check for leakage, see testing instructions.

### Brake hose installation note

When connecting ensure that the brake hose (51) is not twisted. A minimum distance of 15 mm to other axle parts must be ensured in all driving situations.

A retaining plate (60) with 12-point retainer is fastened to the holder (52). Insert brake hose (51) into retaining plate so that it does not chafe with the steering wheel to the left and right lock and the suspension fully extended or retracted.

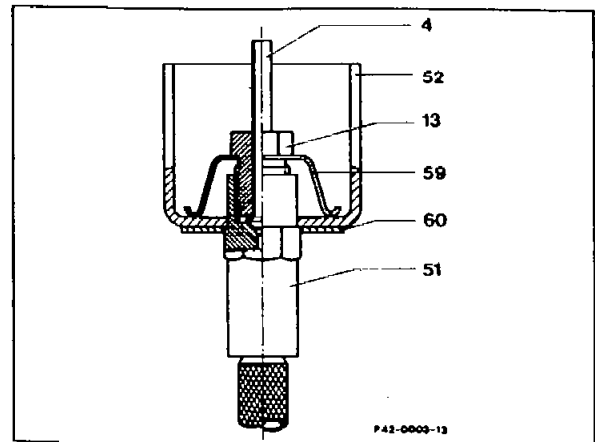

- 4 Brake line
- 13 Union screw
- 51 Brake hose
- 52 Holder on frame floor
- 59 Brake hose holder
- 60 Retaining plate

### Testing instructions

After bleeding, vigorously actuate brake pedal several times so that proper clearance between brake disc and brake pad is obtained. Then perform leakage test with engine running by pressing brake pedal with a pressure of approx. 200–300 N. The brake pressure built up should be maintained without pressing the brake pedal down further. Check all connections for leakage. Add brake fluid to brake fluid supply reservoir, if required.

### Note on fixed callipers

Observe allocation of fixed callipers to individual models (see 42-0150 "Data").

The fixed callipers on one axle must have the same piston diameter. Only install fixed callipers from same manufacturer on one axle.

### Note on disposal

Dispose of used brake fluid as polluting waste.

(See disposal instructions in MBVD Environmental Protection Catalog Chapter 2.6 - pages 2-43). Brake fluid which does not contain oil can be recycled.

This requires that the brake fluid be collected and stored according to type.

For this purpose we recommend using the collection system from the Schröder company described in the MBVD Workshop Equipment Catalog under the following numbers:

- 0210 2200 E 0705 Collection vessel
- 0210 2200 E 0701 Drain vessel
- 0210 2200 E 0702 Hand pump
- 0210 2200 E 0703 Transport rack

The same description is given in the Workshop Equipment Manual, Volume 2, Chapter U, Group 00 (22).

### Special tools

