

P41-5058-55

- | | |
|---|---|
| Vehicle | Lift with column-type lifting platform. Remove and mount road wheels at the rear, 110 Nm. Remove wax layer on rear propeller shaft. |
| Vehicle in speed range which has been criticized | Drive and evaluate. |
| Screw connections | Number consecutively on circumference of flexible coupling (item 5). |
| Balancing nut for M 10x1 (26a, with 1.5 g, 3 g, 5 g are available) | Screw onto projecting threads of hexagon bolt no. 1, start with 1.5 g balancing nut. |
| Balancing washer for M 12 (25a, with 8 g, 10 g, 12 g are available) | Fasten at the hexagon bolt no. 1, start with 8 g balancing washer, while removing the 6 g standard production washer. |
| Vehicle | Lower, evaluate noise characteristics. |

Procedure repeat on all 6 fastening screws. Lock balancing nuts with best result on threads with plug (item 8).

| Designation | Part no. |
|---|---------------|
| Für Sechskantschrauben mit M 10x 1 Gewinde | |
| Balancing nut 1.5 g (1 mm thick) | 124 411 02 72 |
| Balancing nut 3.0 g (2 mm thick) | 124 411 03 72 |
| Balancing nut 5.0 g (3 mm thick) | 124 411 04 72 |
| For hexagon bolts with M 12 thread | |
| Balancing washer 8 g (outside dia. 26 mm) | 124 990 46 40 |
| Balancing washer 10 g (outside dia. 28 mm) | 124 990 47 40 |
| Balancing washer 12 g (outside dia. 30.5 mm) | 124 990 48 40 |

Note

As a remedy against humming noises with rough spots in speed range between 100 to 160 km/h, balancing nuts or balancing washers can be attached to joint flange of rear propeller shaft. But find out first during a test drive whether a complaint is justified. Here, unavoidable dispersions must be allowed for in individual cases during series production, which may be located at upper tolerance limit, so that minor noises should be taken into account.

During test drive of vehicles with manual transmission, check whether vibrations are showing up when decelerating from a high speed. These vibrations **cannot** be eliminated by balancing nuts. In such cases, check whether the centering sleeve is filled with an adequate quantity of grease and whether the propeller shaft is guided free of play in centering sleeve, and renew parts, if required. Prior to assembly fill centering sleeves with approx. 6 g of multi-purpose grease according to page 267 of Specifications for Service Products.

- 1 Lift vehicle on a column-type lifting platform.

Note

If a mobile balancing unit is available, the vehicle can be placed with its rear axle on measuring blocks (overhang 145 mm).

- 2 Remove rear road wheels.

Note

Tightening torque 110 Nm.

- 3 Drive vehicle in speed range complained about for evaluation by a second person on rear seat.

- 4 Lift vehicle and remove wax layer on rear propeller shaft.

5 Number screw connections consecutively along circumference of flexible coupling with numbers 1 - 6.

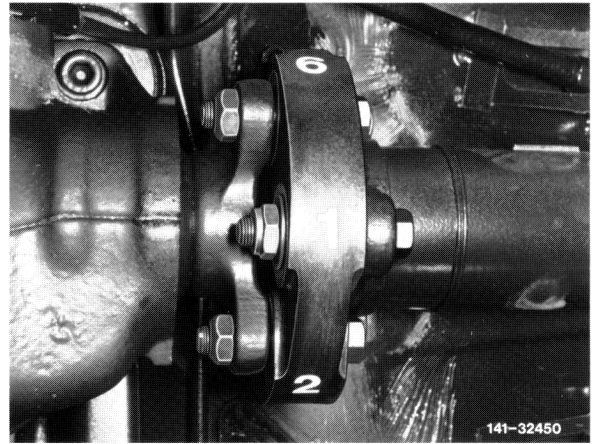

6 Screw a 1.5 g balancing nut (arrow) (1 mm thick) onto projecting threads of hexagon bolt, or mount a balancing washer.

Note

On vehicles with M 12 thread, an 8 g balancing washer is to be mounted, while removing the standard production 6 g washer.

7 Lower vehicle again and evaluate noise characteristics anew.

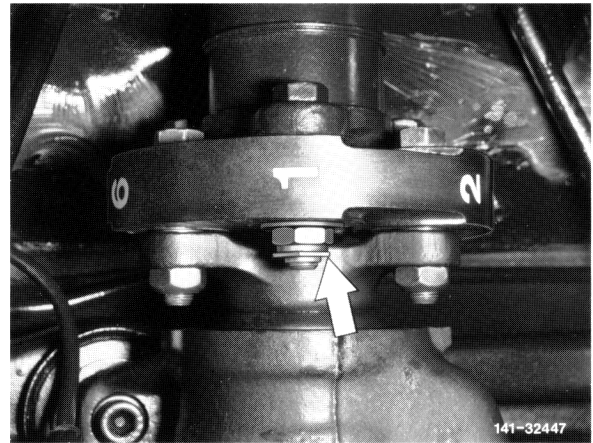

8 Repeat this procedure on all 6 fastening screws, while mounting the balancing nut (arrow) or balancing washer on each of the nearest hexagon bolts. Write down the obtained respective results.

Note

If a satisfactory result has still not been obtained, mount the next larger 3 g or 5 g balancing nut or balancing washer onto the hexagon bolt judged to be the best instead of the 1.5 balancing nut. Then again evaluate noise characteristics.

For additional improvement of noise characteristics a 1.5 g balancing nut or balancing washer can also be attached to one of the adjacent screws (find the most favorable location by driving according to item 3).

The 5 g balancing nut is required in extreme special cases only.

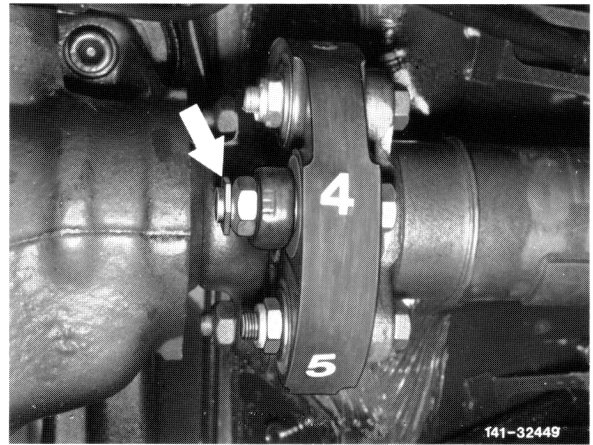

9 Secure the balancing nut or nuts, by means of which the best result has been obtained, on threads with a suitable plug (arrows). On vehicles with M 12 hexagon bolts replace all self-locking hexagon nuts. Tightening torque 60 Nm.

Note

If no balancing nuts are available, the work can also be performed with washers, if required.

