

15-5700 Removing and Installing poly V-belt pulley (fan assembly)

Preceding work:

Fan cowl removed, engine 104
Poly V-belt removed (13-342)
Engine compartment panelling removed (61-0105)
engines 102, 103
Alternator removed (15-5032) engines 104, 111,
119, 974/975, 602, 603, 605, 606
Front noise encapsulation removed (94-5310)

Operation no. of operation texts and work units or standard texts
and flat rates:

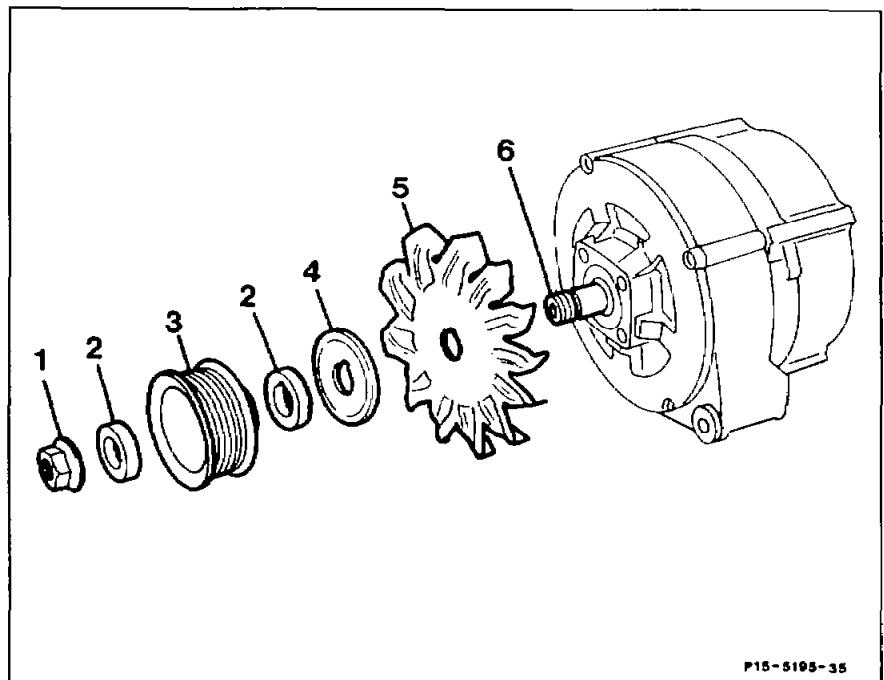

Bowl-type alternator

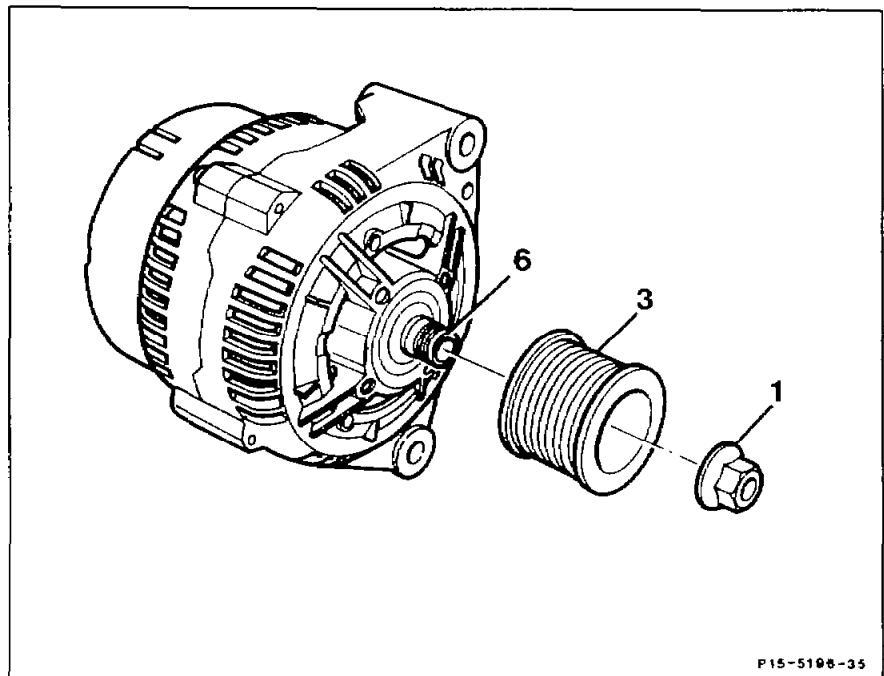

Compact alternator

Ground cable at battery	disconnect, connect.
Collar nut (1)	unscrew, screw on.

"Only bowl-type alternator"
Tightening torque 70 Nm. Use hexagon socket bit (8 mm) with reversing ratchet for holding the shaft (6).

"Only compact alternator"

Tightening torque 80 Nm. Use serrated bit (10 mm) with reversing ratchet for holding the shaft (6).

Only bowl-type alternator

Spacers (2), poly V-belt pulley (3), supporting washer (4), fan wheel (5)	take off, fit on.
---------------------------------------------------------------------------------	-------------------

Only compact alternator

Poly V-belt pulley (3)	take off, fit on.
------------------------------	-------------------

All alternators

Note

The fan wheel is subjected to very different stresses. The level of these stresses depends primarily on the driving conditions. For this reason, when repairing or exchanging alternators on cars which have driven more than 100 000 km, also replace the fan assembly at the same time.

Special tools

