



F6





AR03.30-P-8022A

Checking, remachining flywheel

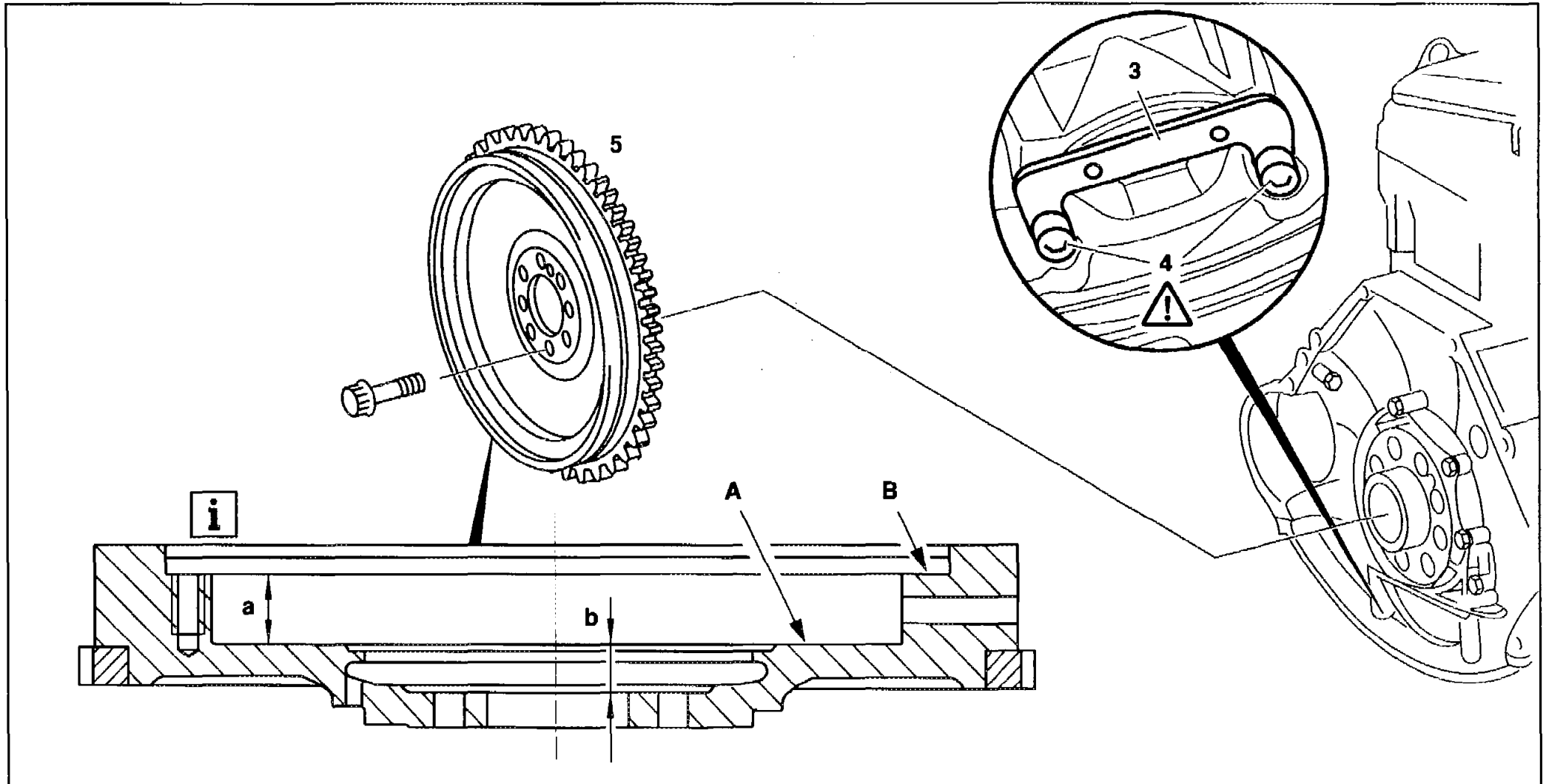
10.2.94

ENGINE 602.982, 604, 605, 606 with TRANSMISSION 717.4



 	Removal, installation		
1	Remove manual transmission		AR26.10-P-0020A
2	Remove clutch		AR25.10-P-0050A
3	Install blocking plate (3, 4) for crankshaft/ring gear	 Use M6×90 bolts otherwise the threads in the rear end cover will be damaged.	AR03.30-P-5000HA H5
4	Remove flywheel, two-mass flywheel		AR03.30-P-8001HA P5
5.1	Remachine flywheel	<p>Measure limits (a, b) for machining.</p> <p>If dimension b is less than the limit or if stock removal on clutch face (A) is greater than 1 mm (dimension a) ↓</p> <p>Replace flywheel</p> <p> If the clutch face (A) is remachined, the mounting face (B) must also be remachined by the same size. Dimension (a) must remain the same.</p> <p> Remachine flywheels with scorch marks, scoring or cracks in the clutch face by precision-turning.</p> <p>If grooves or cracks are deeper than the maximum permissible stock removal ↓</p> <p>Replace flywheel</p>	BE03.30-P-1001-03A



		<p>After machining, there must not be any shrink holes and chatter marks on the clutch face</p> <p>Check radial runout of clutch face and clutch contact face</p>	BE03.30-P-1002-03A
5.2	Check two-mass flywheel	<p>⚠ The two-mass flywheel must not be remachined.</p> <p>Check axial runout. If the permissible difference is exceeded ↓</p> <p>Replace two-mass flywheel</p>	BE03.30-P-1003-03A
6	Install in the reverse order		



Flywheel

Number	Designation	Engine 602.982, 604, 605, 606 with manual transmission	
BE03.30-P-1001-03A	Reference clearance	"a" mm	22.5 ± 0.1
		"b" when new	mm 16.6 ± 0.4
		when for repairs up to	mm 15.6 ± 0.4
		Fig.	AR03.30-P-8022A
BE03.30-P-1002-03A	Permissible radial runout	mm	0.05
BE03.30-P-1003-03A	Permissible axial runout	mm	0.05