

20

Coolant leak through cooling system pressure cap from 110 °C	B 16
Residue smears at coolant pump	B 16
Noises from area of fan coupling, particularly at high engine speeds. Fan runs constantly. Coolant temperature too high (engine overheats)	C 16
Clattering noises particularly when engine cold. When standing in front of vehicle, heard most clearly from radiator lining area	F 16
Automatic transmission oil in cooling system, inside of expansion tank discoloured red	G 16
Fastening nuts for automatic transmission oil cooler fracture	G 16
High coolant temperatures on vehicles which have covered approx. 6000 km or more	H 16
Retrofitting drainage pipe for coolant pump	J 16
Retrofitting vent pipe for cooling system	N 16

22 Engine suspension

Rattling noise at 4000 – 5000 rpm, possibly also when idling, which can be heard from instrument panel or footwell	H 17
Clattering noises when starting and stopping engine (4- and 5-speed transmission)	H 17
Droning noise when starting off, forward or backward. Rumbling noises when starting and stopping engine	J 17
Inspecting hydraulic engine mounts	K 17

22 Hydraulic engine mounts

Complaint:

Rattling noise at 4000 – 5000 rpm, possibly also when idling, which can be heard from the instrument panel or from the footwell.

Cause/Remedy:

Riveted stop plate in the bottom chamber of the hydraulic engine mount loose.

Renew hydraulic engine mount.

Rattling or clattering noises when starting and stopping engine (4- and 5-speed transmission).

Cause/Remedy:

Vibrations of the engine-transmission block through the longitudinal axis briefly excites the transmission gear set when the engine is started or stopped, as a result of the clearances required for gearwheels and synchronizer rings.

There is no remedy for this complaint.

Complaint:

**Droning noises when moving off, forward or back.
Rumbling noises when starting and stopping engine.**

Models 124.130/190

Cause/Remedy:

The rubber part in the supporting body has settled excessively.

Install engine mount 201 240 28 17.

Production breakpoint: 11/86

Complaint:

Inspecting hydraulic engine mounts

Models 124 (except 124.034 and 124.036) and 201 (as of 10/84)

General

The extent of settling of the hydraulic engine mounts can be determined with a bolt (13 mm width across flats) or with a shop-made inspection gauge (see drawing).

This work should only be performed if rumbling and droning noises exist, before replacing the engine mounts.

Inspection procedure

Remove bottom engine compartment panel, install. Push inspection gauge from below between engine mount and cross member on the side facing toward engine (arrow).

If it is not possible to push the gauge through, the engine mount has settled too much and should be replaced.

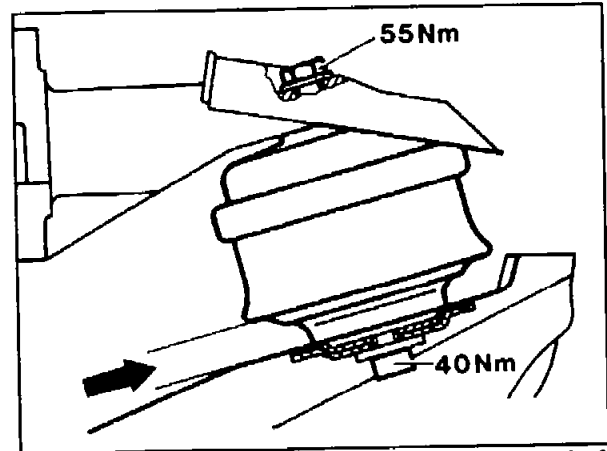

P22-5043-13

If the gauge can be pushed through, the entire engine suspension must be stress-relieved as follows.

Procedure:

- Unscrew the bolt securing the rear engine mount at the engine support.
- Detach exhaust bracket at transmission.
- Detach exhaust at exhaust manifold.
- Slacken bottom bolts securing front engine mounts.
- Slacken top securing bolts.
- Raise engine until the engine mounts are just clear (engine mounts can be turned by hand).
- Lower engine.
- Tighten bottom securing bolts, tightening torque 40 Nm.
- Tighten top securing bolts, tightening torque 55 Nm.
- Align rear engine mount (Y direction).
- Allow suspension to settle at rear by raising transmission 2 – 3 times **vertically by hand** and lowering.



If the threaded holes (rear engine mount) are not aligned with the hole (engine support), slacken engine support and align.

- Tighten transmission bolts, tightening torque 25 Nm. If necessary, tighten engine support, tightening torque 40 Nm.
- Tighten exhaust evenly at exhaust manifold, tightening torque 25 Nm.
- Tighten exhaust bracket at transmission, tightening torque 25 Nm.
- Install bottom engine compartment panel.

Shop-made tool

Inspection gauge

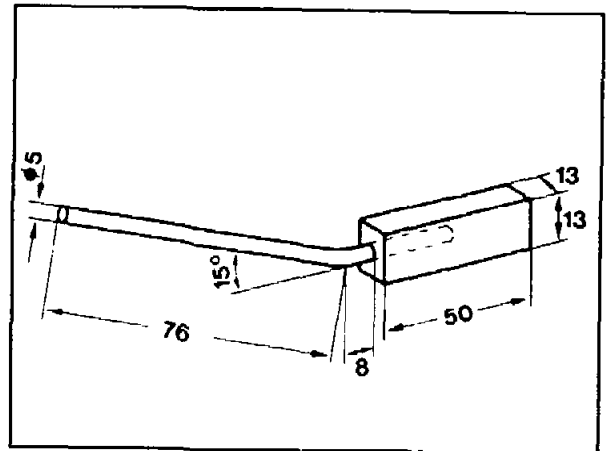

P22-5030-13