

47-0030 Function of Fuel Tank Ventilation

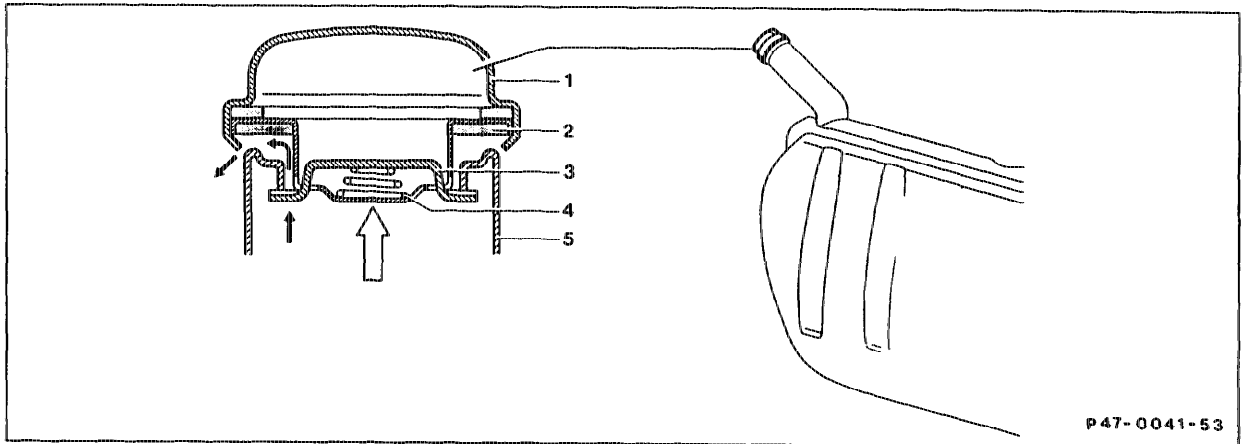

All models

- | | | | |
|---|--------------|---|--------------------|
| 1 | Cap | 4 | Compression spring |
| 2 | Sealing ring | 5 | Filler neck |
| 3 | Closing bar | | |

At a gauge pressure of 100–300 mbar, the fuel vaporization gases can escape through the cap. This is only the case, if e.g. the vent line from the fuel tank is not clear. If the system is operating properly, a gauge pressure of up to 50 mbar may occur in the fuel tank.

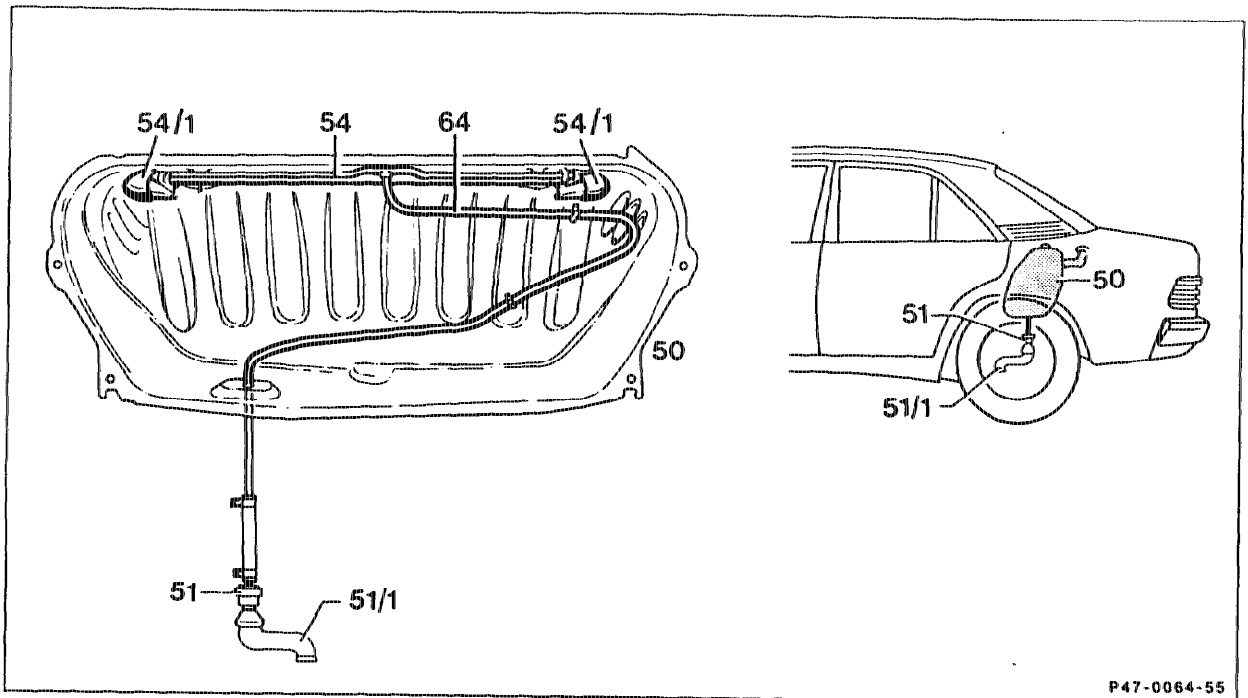

The vent system in the fuel tank (50) consists of a central pipe (54) each with an interruption vessel (54/1) at the ends.

The interruption vessels prevent fuel escaping along the vent line.

The vent line (64) runs from the central pipe to the vent valve (51). The protective seal (51/1) at the end of the vent valve prevents dirt and splash water from getting into the vent valve.

If a gauge pressure of 30–50 mbar is reached in the fuel tank, the vent valve (4) opens and allows the fuel vapours to escape.

- 1 Compression spring
- 2 Valve housing
- 3 Spring plate
- 4 Vent valve
- 5 Valve plate
- 6 Air admission valve
- 7 Connection fitting

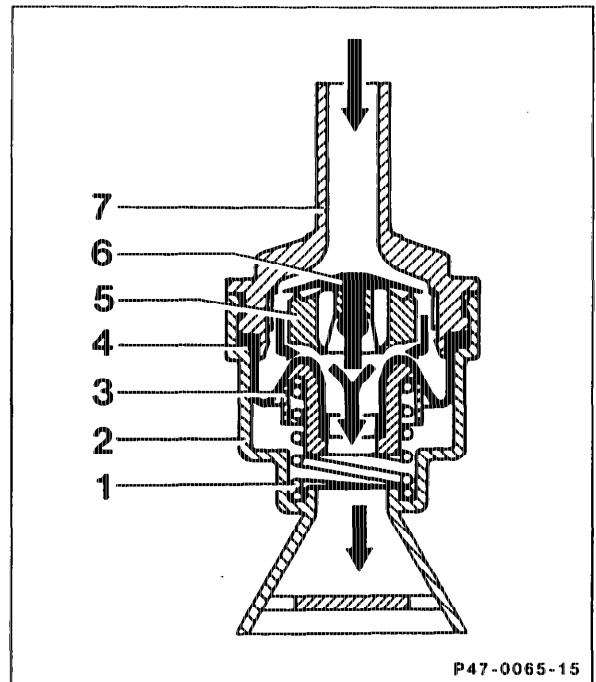

If a vacuum of 1–16 mbar is produced in the fuel tank, the air admission valve (6) opens.

Station wagons (USA)

These models are fitted with a modified vent valve with a bright base section. The test data are the same as for other vent valves.

- 1 Compression spring
- 2 Valve housing
- 3 Spring plate
- 4 Vent valve
- 5 Valve plate
- 6 Air admission valve
- 7 Connection fitting

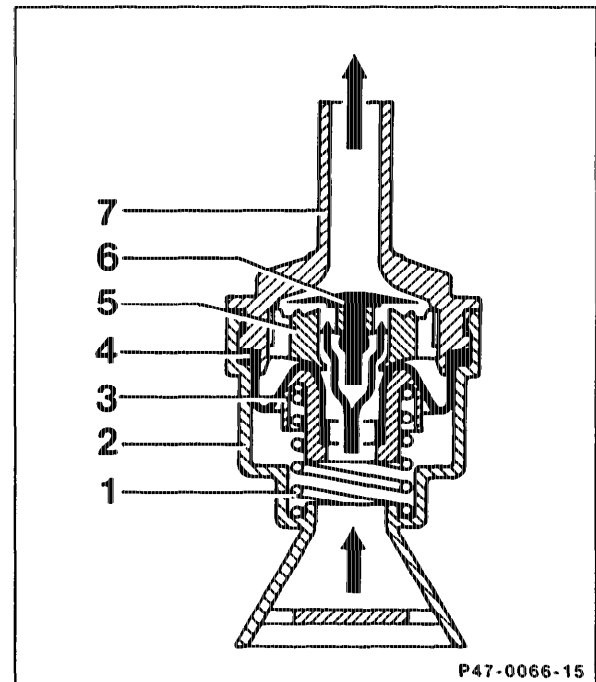

The dirt seal at the end of the vent valve prevents dirt and splash water from getting into the vent valve.

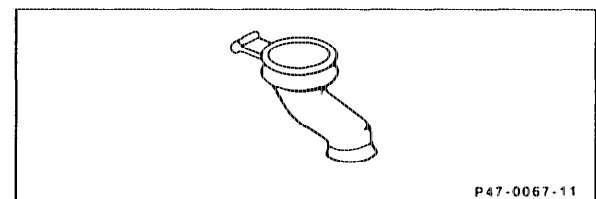

Modified vent system

The vent system has been modified by additional lines and interruption vessels (arrows) with the result that no fuel can escape through the vent system, even under extreme conditions (rollover).

Production breakpoint: phased in (approx. 10/88).

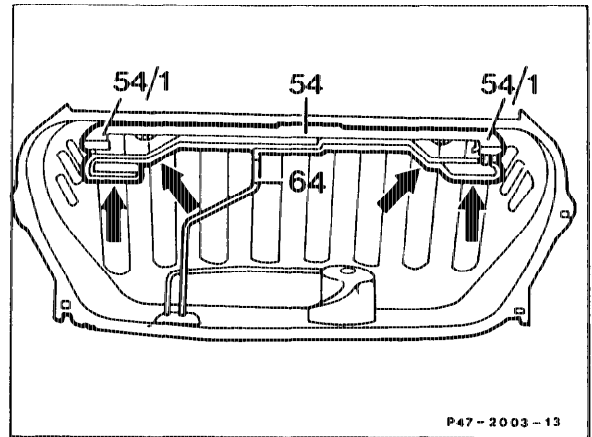

Model 201 plastic fuel tank

The plastic fuel tank is shaped in the top area (arrows) in such a way as to create the function of the vent system (central pipe).

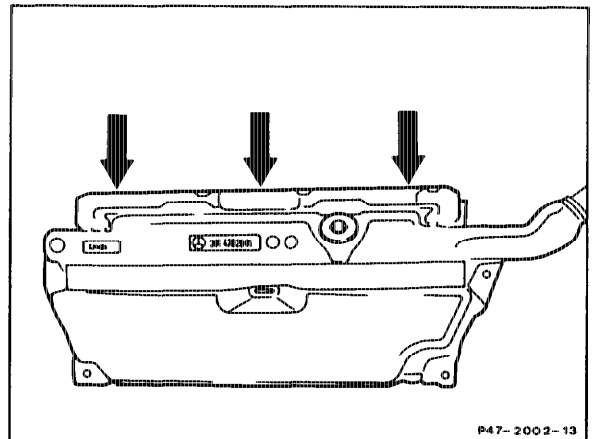

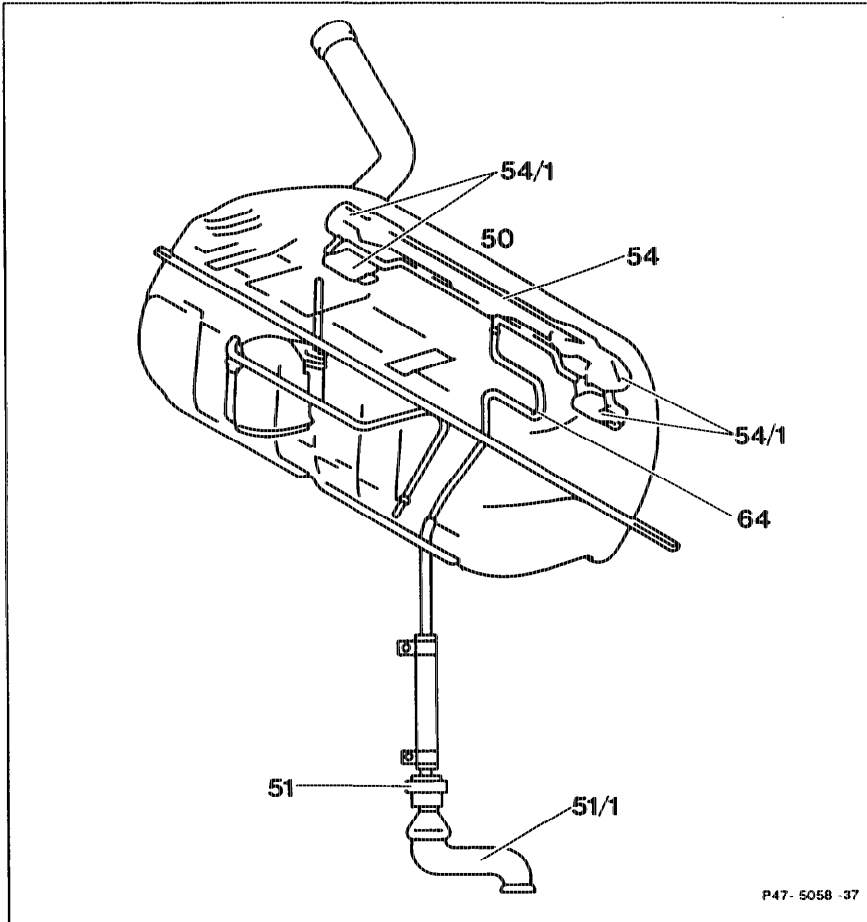

The vent system consists of a central pipe (54) with interrupt vessels (54/1) at the ends.

The interrupt vessels (54/1) prevent fuel escaping along the vent line. The vent line (64) runs from the central pipe to the vent valve (51).