

18-002 Engine oil and filter change

Operation no. of operation texts and work units or standard texts and flat rates

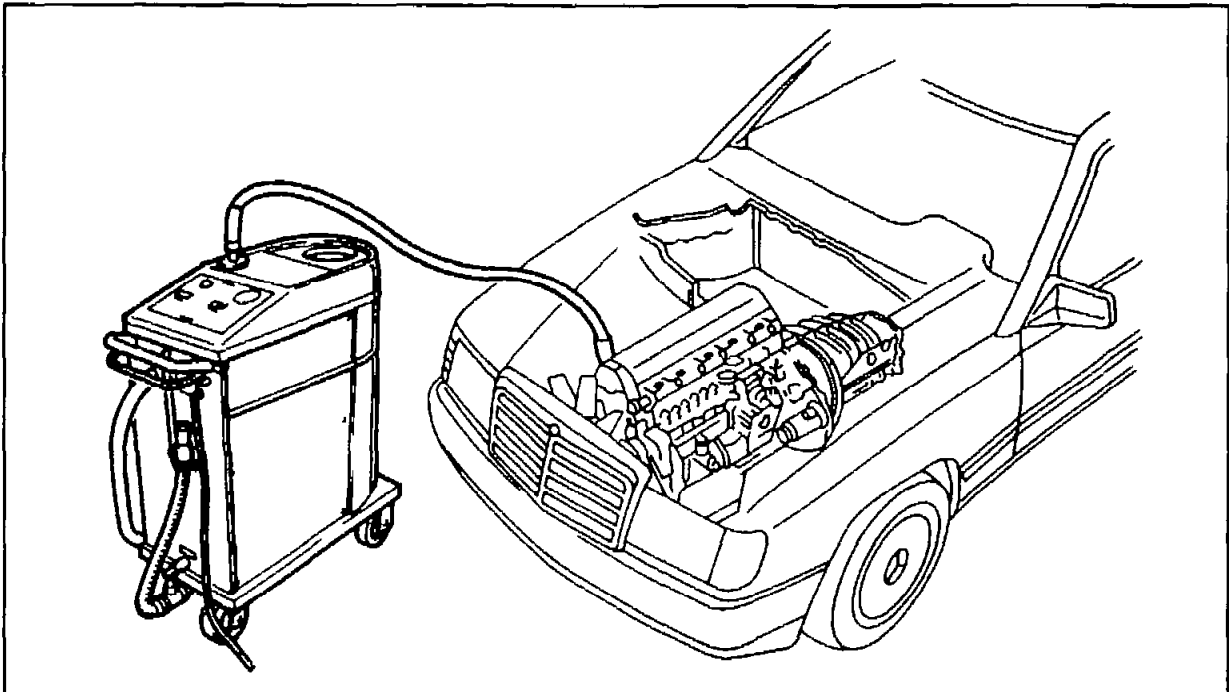

P18-0118-55

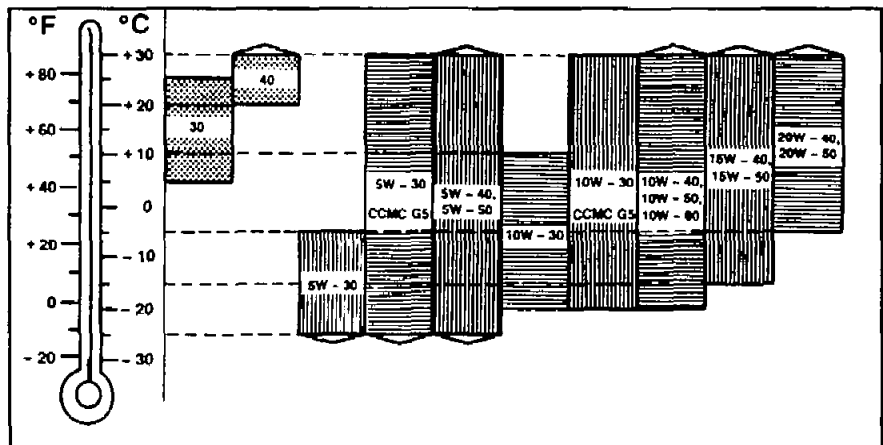

P18-5179-33A

Specified and approved quality stages and viscosity classes conforming to SAE for continuous outside temperatures

Engine oils which comply with a test sequence conforming to CCMC are approved. Oils conforming to the API (American Petroleum Institute) Classification may also be used only in countries in which oils conforming to CCMC are not available.

Precise application of the SAE classes on the basis of outside air temperatures would necessitate frequently changing the engine oil. The temperature limits for the SAE classes should therefore be regarded as a guide line and actual temperatures may be higher or lower than these limits for short periods.

Engine oils of the same quality stage may be intermixed (for example CCMC G5/PD2 or API SG/CE as a possible combination).

See "Service Product Specifications" for further information on specified viscosity classes and approved engine oils.

Oil capacity in liters

Engine	Model	Capacity for oil and filter change	Colored marking		
			Colored marking	Colored marking	Numerical marking on handle (color red)
			Round handle	Handle shaped like bottle opener	
601	124. 201. 202	6	black	–	–
602.91	124. 201	6.5	–	–	60214 ¹⁾
		7 ²⁾	–	green ²⁾	–
602.982	210	7	–	–	60214
602.96	124. 201	7	–	green ³⁾	–
603.91	124	7	–	black	–
603.96	124	7.5	–	black	–
603 4MATIC	124	7.5	–	enzian blue	–
603.96/ 970	126 (USA)	7.5	–	–	60316
603.971	140 (USA) ⁴⁾	8.0	–	–	60324

¹⁾ 1st version – red colored marking

2nd version – black colored marking

3rd version – brown colored marking

²⁾ On engines with exhaust gas recirculation and side part on oil sump

³⁾ 1st version black

⁴⁾ As of January 1993 ECE

Tightening torques

Nm

Oil filter cover fastening nuts		25
Screw of oil filter cap		25
Oil drain plug of oil sump	M12 × 1.5 × 13	30
	M14 × 1.5 × 22	25
Return pipe in oil filter cover ¹⁾		25

¹⁾ Only engine 603 in model 124

Special tools

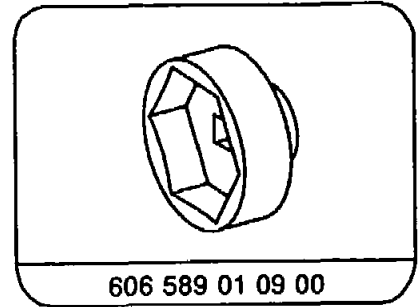
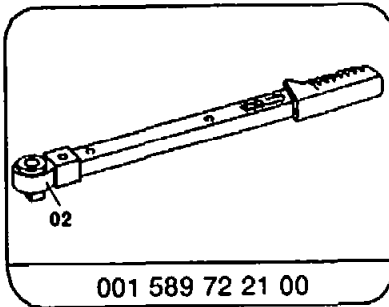
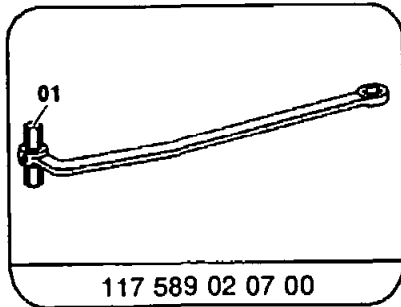

Commercially available tool

Engine oil extractor

e.g. Deutsche Tecalimit
Am Metallwerk 11
33659 Bielefeld

Note

On 4MATIC models, open only drain plug (5) on the large oil sump (4).

On models with air-to-oil cooler (turbo engines) the oil does not need to be drained from the air-to-oil cooler.

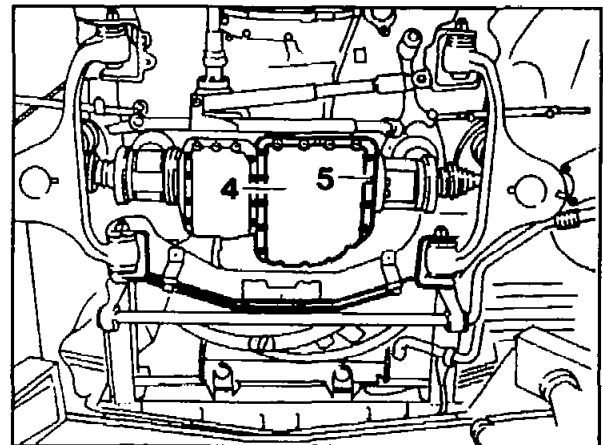

P01-2461-13A



The filter element and the rubber seal on the oil filter cover must not be confused with that of engines 615, 616 and 617 as these are different in size.

Engines 601, 602, 603

Size L1 113 mm

L2 49 mm

Engines 615, 616, 617

Size L1 131 mm

L2 55 mm

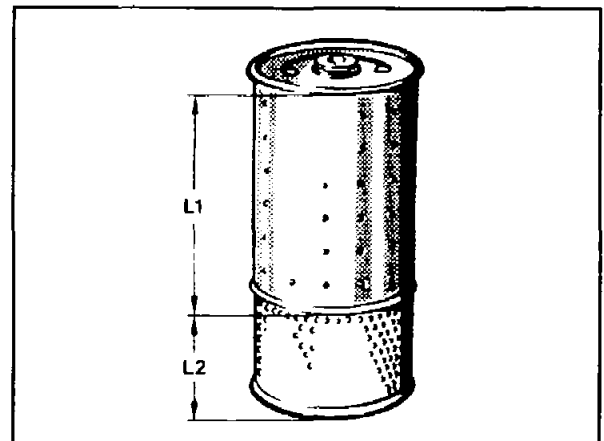

P18-0083-13



Change engine oil only when engine at normal operating temperature.

- 1 Empty oil filter before extracting or draining the engine oil. This is done by unscrewing the nuts (arrows) and taking off the cover.

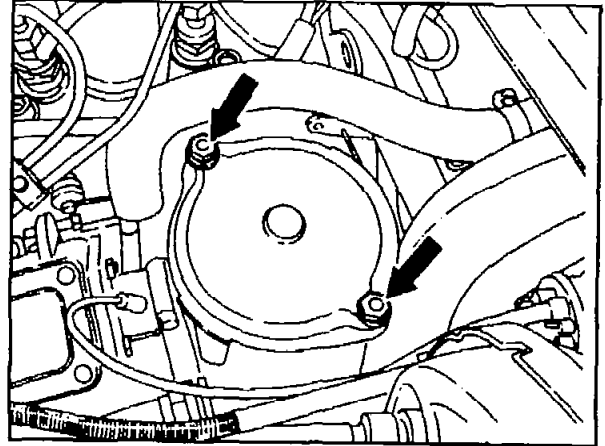

P18-2046-13

For reasons of space, when performing this step on engine 603 in model 124 (up to 01/86), detach rubber gasket or sealing strip on the component partition wall in the manner described below, and pull up slightly.

Divided rubber gasket

Pull off retaining clip (1).

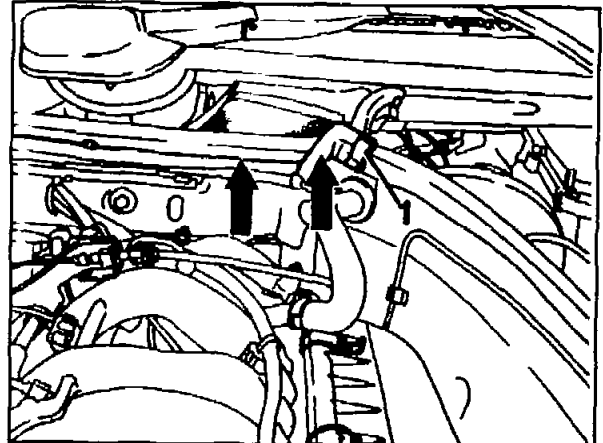

P18-2059-13

One-piece rubber gasket

Remove screw (arrow).

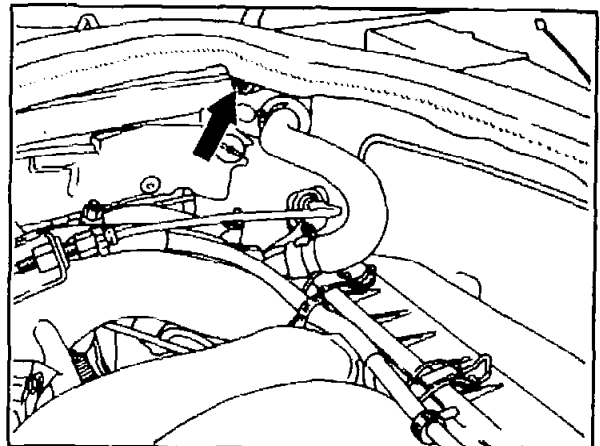

P18-2060-13

2-part oil filter cover

(effective 02/86, engine 603 in model 124)

Unscrew return pipe (276) and take off. Unscrew oil filter cover fastening nuts and take off cover.

- 2 Extract engine oil through the dipstick guide tube when engine at normal operating temperature.

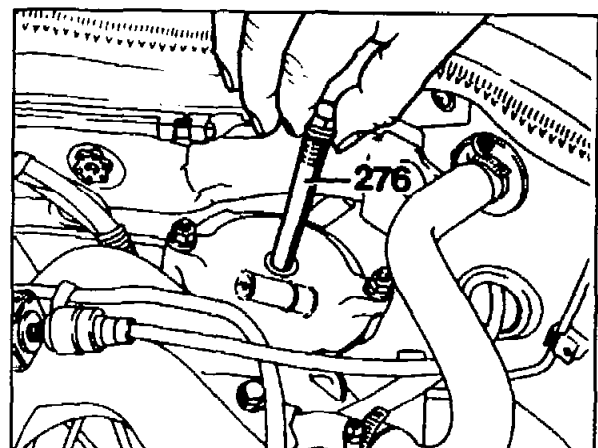

P18-2061-13

Engine 601 in model 202 and engine 602 in model 210 with oil-water heat exchanger at oil filter

3 Remove screw cap (2) with wrench bit 606 589 01 09 00 and take off together with oil filter element (4).

4 Replace seal (3).

5 Insert new oil filter element (4) into oil filter housing.

6 Fit on screw cap, use wrench bit 606 589 01 09 00.

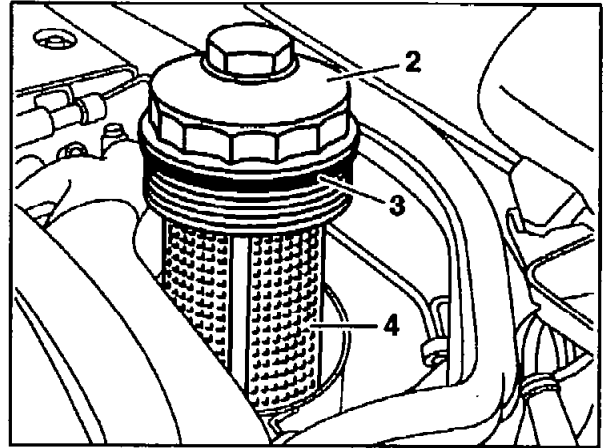

P18.00-0212-01

If no extractor is available:

7 Remove engine compartment cladding below (01-006).

8 Drain engine oil out of sump (arrow).

Note

The oil in the air-to-oil cooler does not need to be drained.

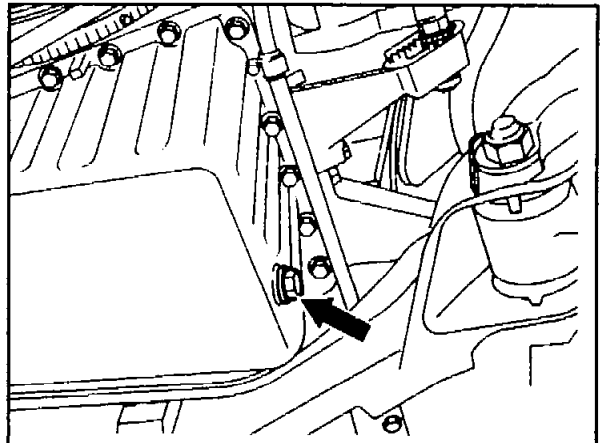

P01-2348-13

9 Renew filter element.

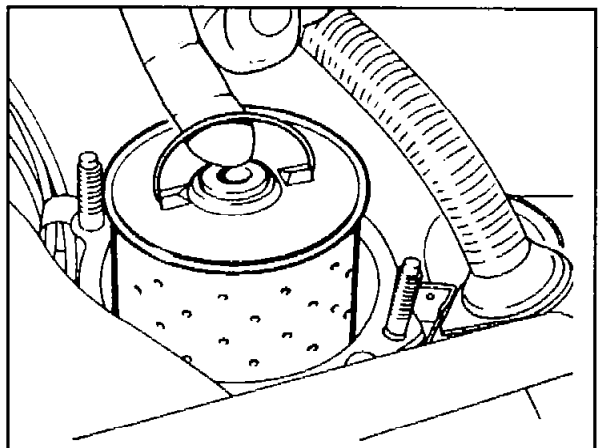

P18-2062-13

10 Renew rubber seal (1) on the cover.

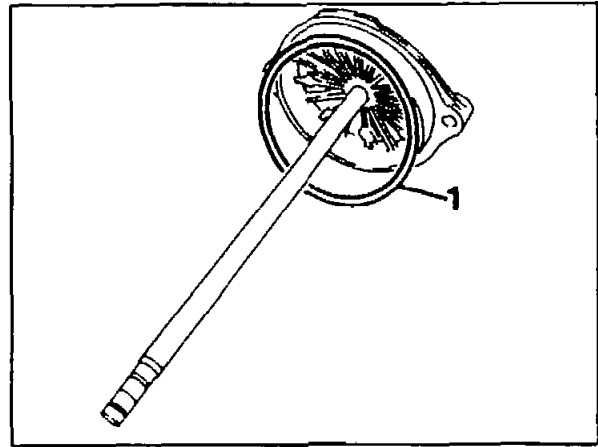

P18-2057-13

11 Examine restriction opening on oil pipe for foreign bodies (arrow). If it is blocked, remove foreign bodies by hand. Following this, blow compressed air into restriction opening. Air must be felt to escape at the bottom of the oil pipe. If the restriction opening is not free or if no air flows out, renew oil filter cover together with oil pipe.

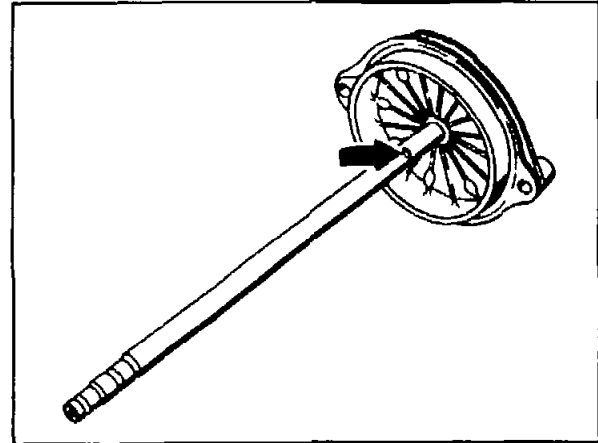

P18-0111-13

12 Tighten nuts and return pipe to 25 Nm.

13 If the oil has been drained from the sump, renew sealing ring of oil drain plug.

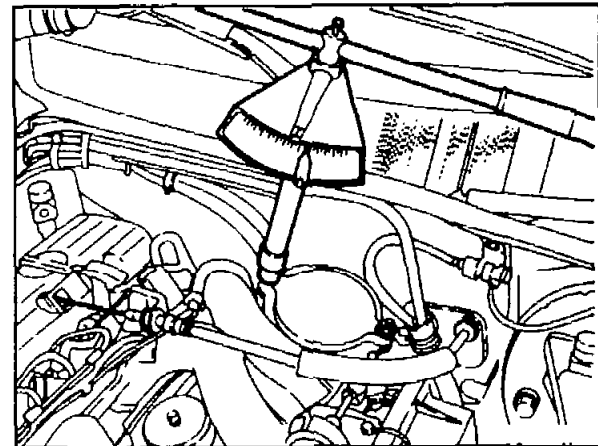

P18-2063-13

14 Tighten oil drain plug to 30 or 25 Nm, respectively.

15 Pour in engine oil.

16 Run engine and examine for signs of leaks.

17 Check oil level approx. 2 minutes after switching off engine at normal operating temperature.

18 Install engine compartment cladding below (01-006).

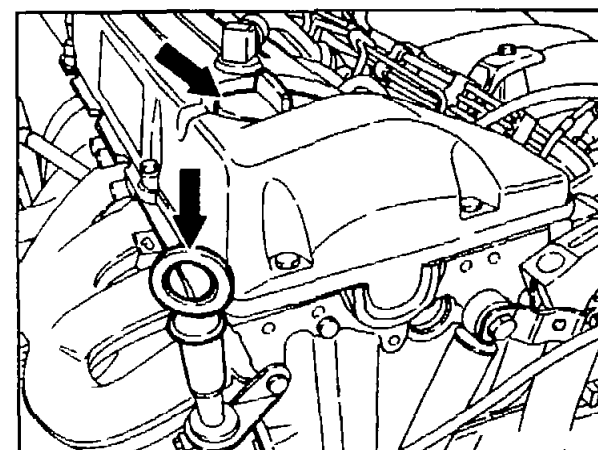

P18-2064-13