

05-285 Checking and replacement of valve guides

Preceding work:
 Cylinder head removed (01-415).
 Valve springs removed (05-250).
 Valves removed.

Operation no. of operation texts and work units or standard texts
 and flat rates
 05-3731

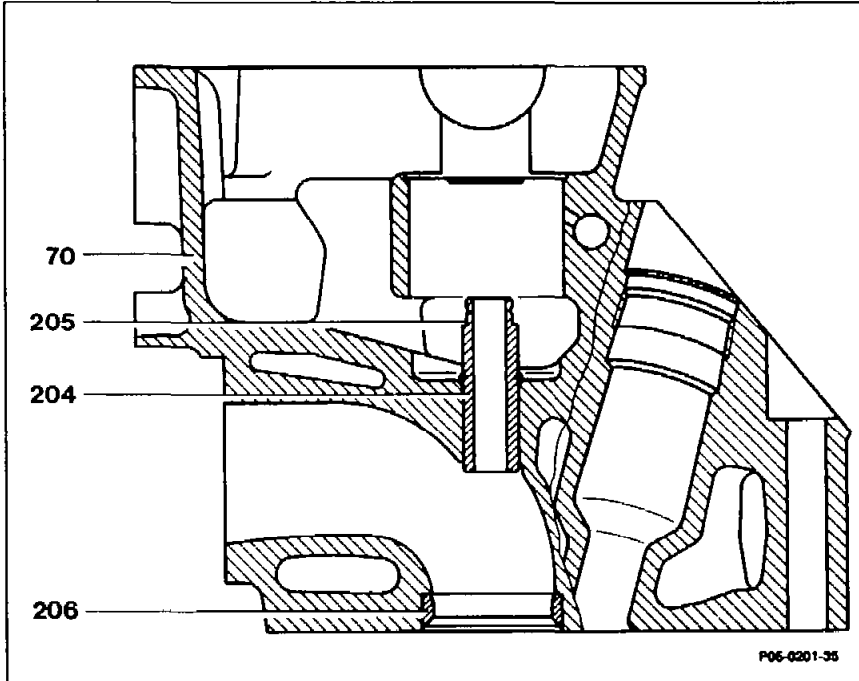

Checking

Seat for valve stem seal (205)	check. Replace valve guide (204) if valve stem seal is loose.
Valve guide (204)	clean. Cylindrical brush 000 589 10 68 00.
Valve guide (204) inside dia.	check. Plug gauge: 102 589 00 23 00 intake, 117 589 03 23 00 exhaust. Replace valve guide, if reject pin of plug gauge fits completely in the valve guide.

Replacement

Valve guide (204)	drive out, drive home. Drift: 103 589 03 15 00 intake, 103 589 02 15 00 exhaust. Punch: 601 589 06 15 00 intake, 601 589 02 15 00 exhaust. Ream, Reamers: 000 589 21 53 00 intake 000 589 10 53 00 exhaust
-------------------------	--

Basic bore of valve guide
in cylinder head (70)

check. If required bore out to next
repair size.
Broach (14.20 mm) 115 589 00 53 00.
Guide sleeves:
102 589 00 63 00 intake,
102 589 08 63 00 exhaust.
Broach (14.40 mm) 115 589 01 53 00
Guide sleeve 601 589 15 63 00.

Valve seat insert (206)

check for eccentricity (05-291).

Valve guides (grey cast iron)

	Version and Part No.	Outside dia. (D)	Color marking	Basic bore in cylinder head	Overlap	Valve guide inside dia. (A)	Length (L)
Intake	Repair size I 601 050 07 24	14.240-14.251	red	14.200-14.211	0.029-0.051	8.000-8.030	39.5
	Repair size II 601 050 08 24	14.440-14.451	white	14.400-14.411			
Exhaust	Repair size I 601 050 10 24	14.240-14.251	red	14.200-14.211	0.029-0.051	9.000-9.050	37.7
	Repair size II 601 050 11 24	14.440-14.451	white	14.400-14.411			

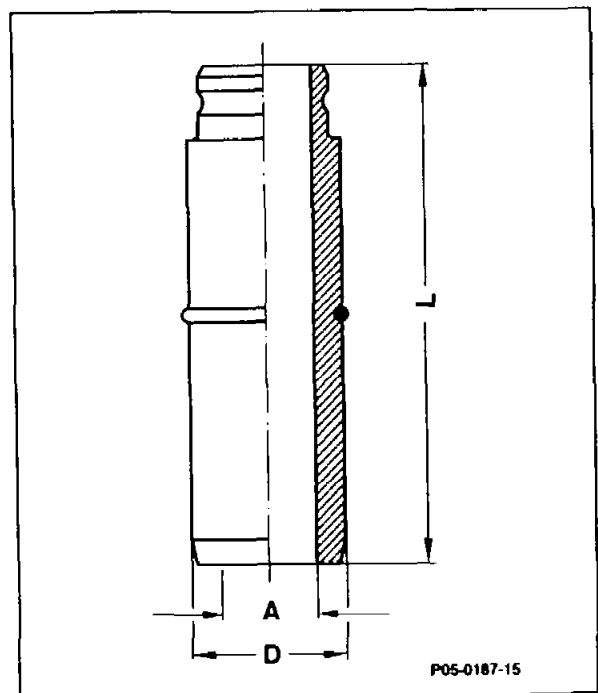

Special tools

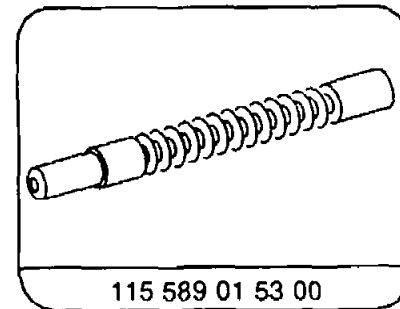
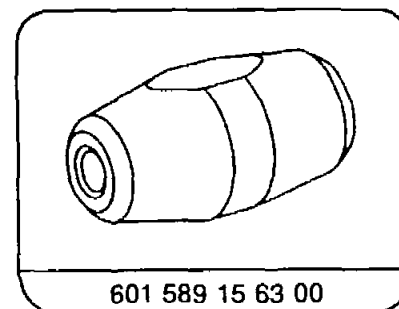
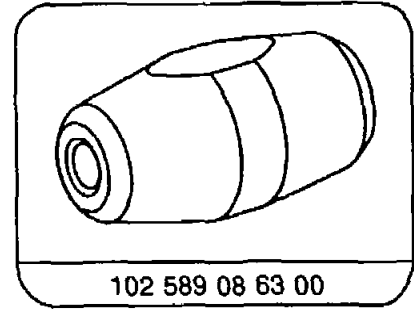
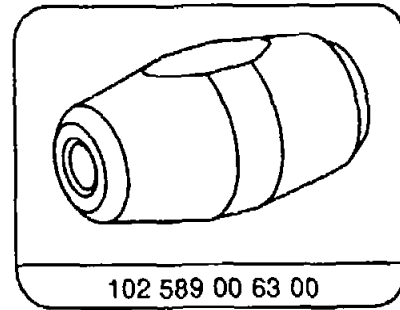
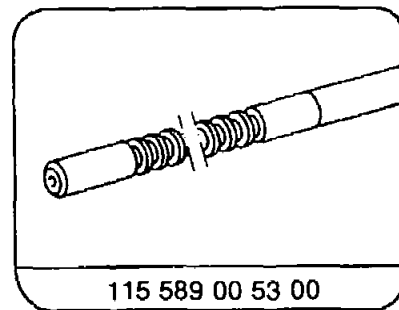
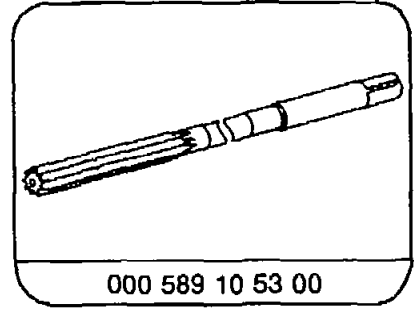
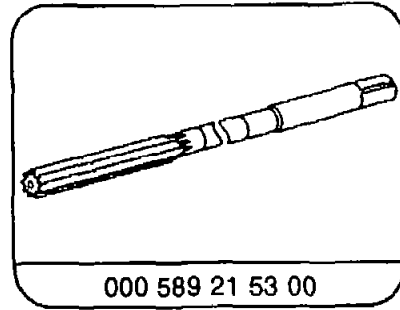
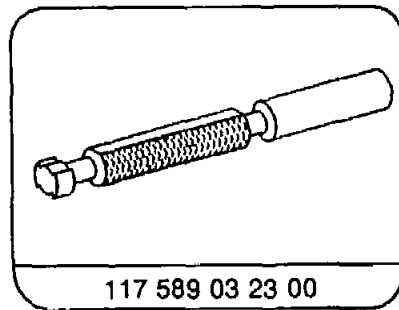
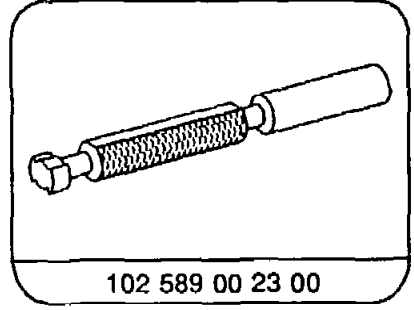
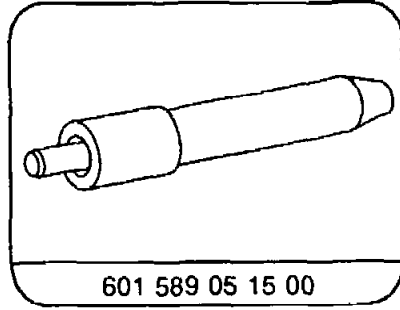
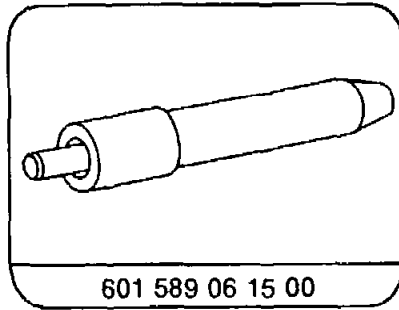
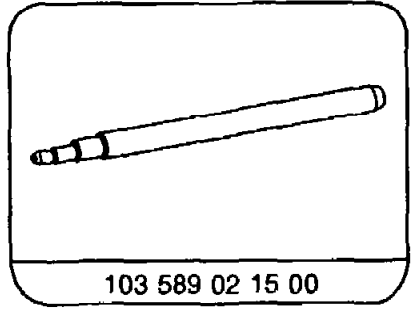
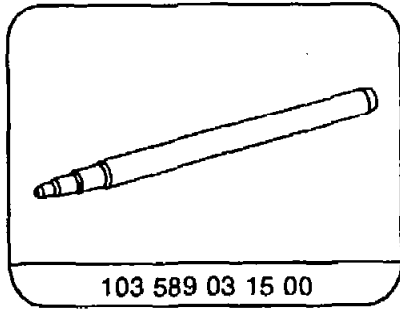
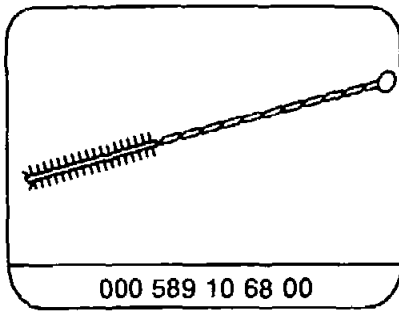

Commercially available tools and testers

Designation	e.g. Make	Order no.
Cylinder head clamping device	Hunger D-81375 München Gräflingerstr. 146	221.60.000

Broach base bore in cylinder head (Repair stage)

Decarbonize and clean cylinder head perfectly, particularly the inside of the valve seat inserts. Select correct guide sleeve (2) and remove swarf from the cutters of the broach (1) with a stiff plastic brush or the like.

Note

The broach cutters must be cleaned before each broaching operating.

Provide guide sleeve, basic bore and complete broach with ample supplies of paraffin.

Insert broach into the guide sleeve so that when the guide sleeve rests on the valve seat insert (3) the first cutter of the broach is located in the base bore. In so doing note that the correct side of the guide sleeve is put on the valve seat. Centre guide sleeve by rotary movements in the valve seat insert.

Note

Drive the broach briskly through with an aluminium mandrel, approx. 130 mm long, and a plastic hammer of approx. 250 g.

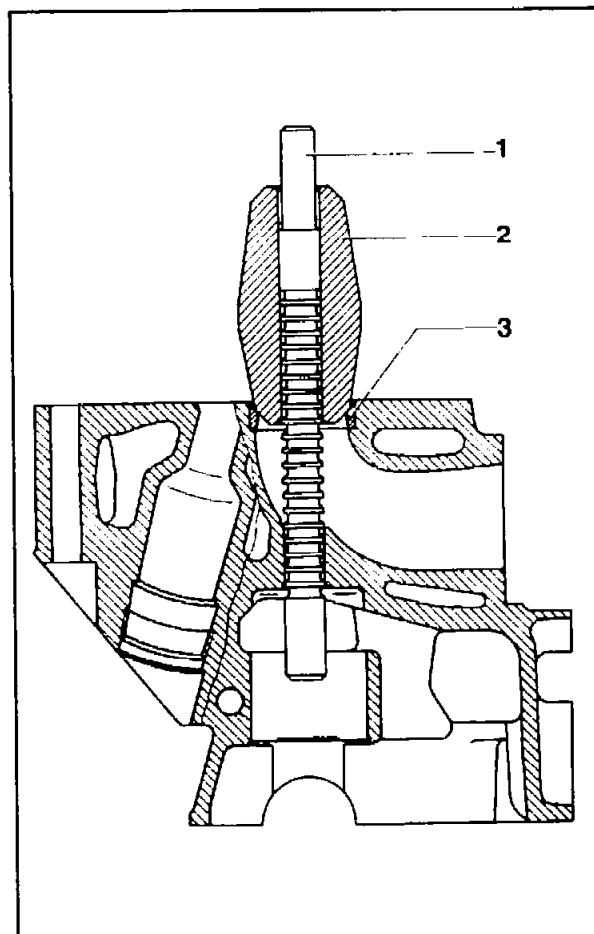

P05-0163-17

Note

The high spot (arrow) on the intake valve seat inserts is to be removed before inserting the guide sleeve.

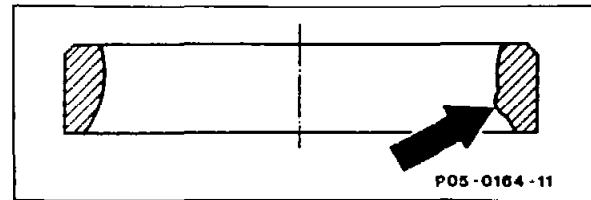
**Inserting valve guide**

Drive home valve guides with punch and hammer, when the valve guides are not super-cooled and the cylinder head is not heated up. Coat valve guides with tallow or oil before driving home.

Assignment of guide sleeve - valve seats

Valve seat	Guide sleeve Part No.	Basic bore dia. in cylinder head
Intake	102 589 00 63 00	14.2 mm
Exhaust		
Intake	601 589 15 63 00	14.4 mm
Exhaust		