

ENGINE 601, 602, 603 (except, 602.982)**1, 2, 3 Measuring points of cylinder bore**

- A** Longitudinal direction
B Transverse direction

- a** Top reversal point of 1st piston ring
b Top dead center of piston
c Bottom reversal point of oil scraper ring

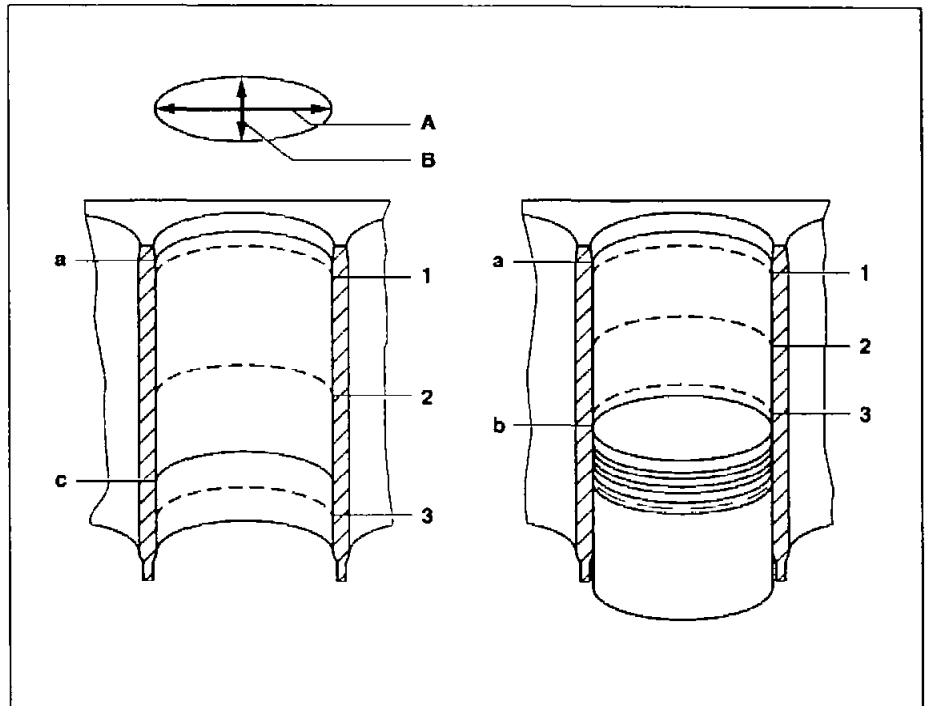

P01.40-0228-06

Fig. item, etc.	Work instructions		
i	When carrying out repairs on engines 601.91/92, 602.91/96, 603.91/96 (naturally aspirated engines), install oversize pistons or cylinder liners with standard size pistons. On engines 603.970/971 (turbo engines) install cylinder liners and standard size pistons.		
	Pistons	remove	AR03.10-P-7021AW
	Cylinder bores	<p> Measure cleaned cylinder bores with internal measuring instrument at the 3 measuring points (1, 2, 3) in the longitudinal and transverse direction.</p> <p> Cylinder diameter</p> <p>Permissible variation of cylinder shape (when new).</p> <p>Wear limit in longitudinal and transverse direction.</p> <p>Out-of-roundness</p> <p>i If excessive wear and/or damaged contact surface ↓</p> <p>Naturally aspirated engines Install repair size pistons, for this step ↓</p>	<p>001 589 53 21 00</p> <p>WH58.30-Z-1054-12A</p> <p>BE01.40-P-1001-01E</p> <p>BE01.40-P-1004-01E</p> <p>BE01.40-P-1003-01E</p> <p>BE01.40-P-1005-01E</p>

		Bore and hone cylinder bores or as on turbo engines ↓	AR01.40-P-9291AW AR01.40-P-9291AW
		Turbo engines Install cylinder liners and standard size pistons, for this step ↓	
		Widen cylinder bore in crankcase ↓	AR01.40-P-9271AW AR01.40-P-9271AW
		Install cylinder liner	AR01.40-P-9273AW AR01.40-P-9273AW
		Bore and hone cylinder bores	AR01.40-P-9291AW AR01.40-P-9291AW
		Engines fitted with cylinder liners ↓ (already reconditioned engines)	
		Remove cylinder liner ↓	AR01.40-P-9272AW AR01.40-P-9272AW
		Install cylinder liner ↓	AR01.40-P-9273AW AR01.40-P-9273AW
		Bore and hone cylinder bores	AR01.40-P-9291AW AR01.40-P-9291AW

Test data of cylinder bore

Number	Designation		Engine 601, 602 except 602.98, 603 except 603.97	Engine 603.97
BE01.40-P-1001-01E	Cylinder Ø	Standard size	mm 87.0	89.0
		Group code letter A	mm 87.000–87.006	89.000–89.006
		Group code letter X	mm 87.007–87.012	89.007–89.012
		Group code letter B	mm 87.013–87.018	89.013–89.018
BE01.40-P-1003-01E	Cylinder bore	Wear limit in longitudinal and transverse direction	mm 0.20	0.20
BE01.40-P-1004-01E	Cylinder bore	Permissible variation of cylinder shape (when new)	mm 0.007	0.007
		Wear limit	mm 0.05	0.05
BE01.40-P-1005-01E	Cylinder bore	Out-of-roundness	mm 0.07	0.07

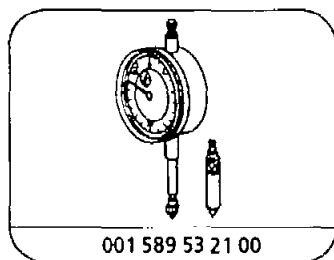

001 589 53 21 00

Dial gage

Commercially available tools (see Workshop Equipment Manual)

Number	Designation	Make (e.g.)	Order number
WH58.30-Z-1054-12A	Internal measuring instrument for 80–100 mm \varnothing with 0.01 mm indication and measuring point pressure relief	Hahn und Kolb Borsigstr. 50 70469 Stuttgart	33 520 080

