

A. Engine 601

Cylinder block/crankcase (starting 10/84)

On this cylinder block the hole for the fitted sleeve (for locating the cylinder head) has been moved farther toward the rear (shaded circle) and the oil passage (1) farther toward the front.

A 1st version

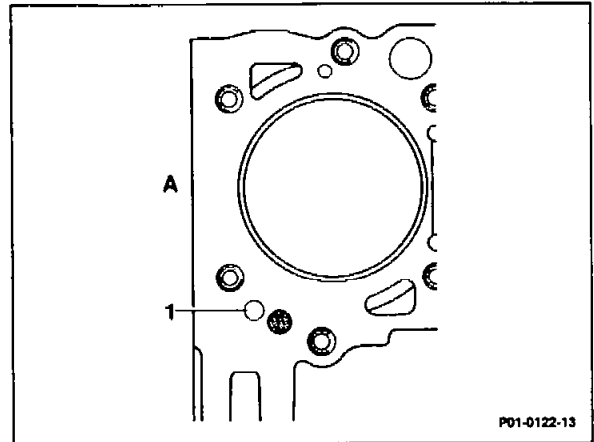

B 2nd version

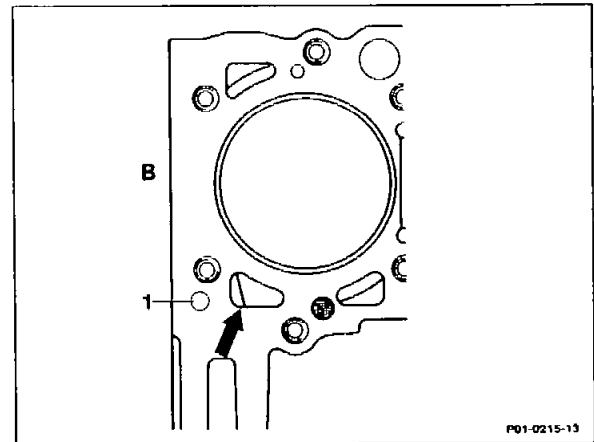

Cylinder head:

The following modifications were necessary due to the new positions of the fitted sleeves and oil passages in the cylinder block.

A 1st version

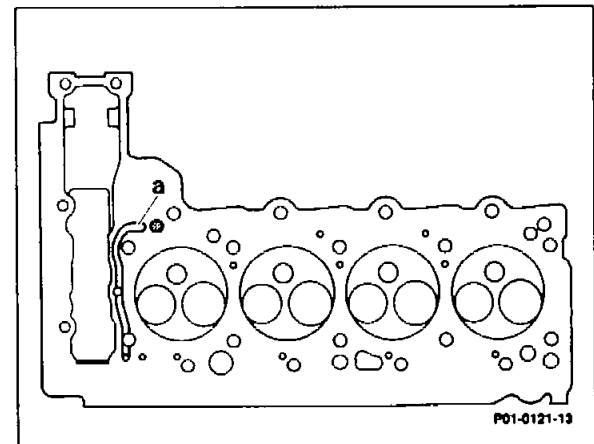

The fitted sleeve centering was moved farther toward the rear (shaded circle). The lateral groove (a) for lubrication of the camshaft bearings and the hydraulic elements is shorter.

B 2nd version

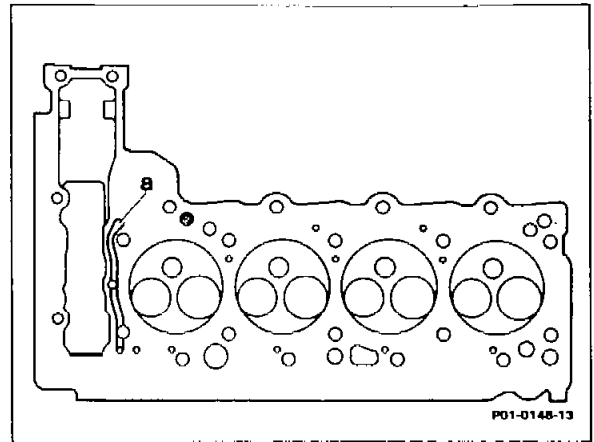

Cylinder head gasket:

The cylinder head gasket was also modified to match the new positions of the fitted sleeves and oil passage in the cylinder block.

A 1st version

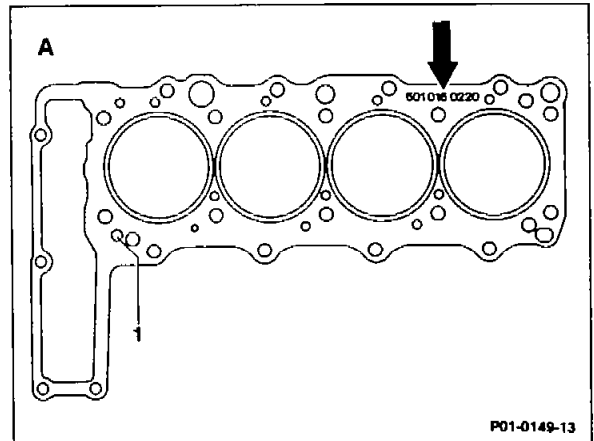

B 2nd version
1 Oil passage for transverse groove in cylinder head

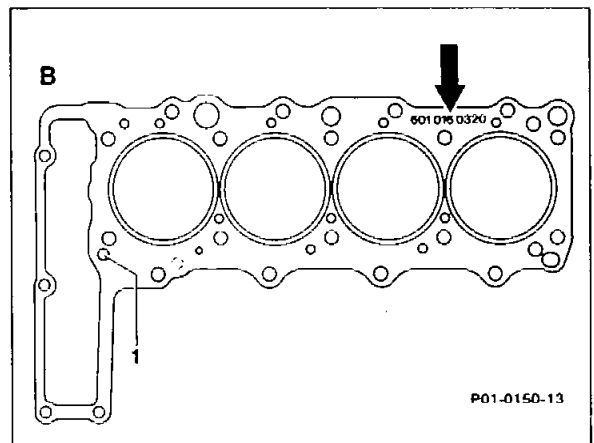

Precombustion chamber mounting bore

As of 04/85 the height (H1) of the thread in the precombustion chamber mounting bore was increased

2 mm for a total of 15 mm.
Dimension H2 is 22.5 mm.

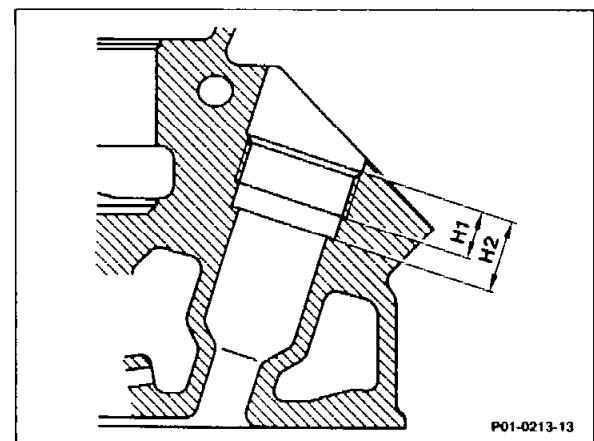

Cylinder head gasket

A cylinder head gasket from a different manufacturer (Ering) was installed for a short time (from 04–05/88).

On this cylinder head gasket the oil return duct (showing in circle) is equipped with a Viton seal.

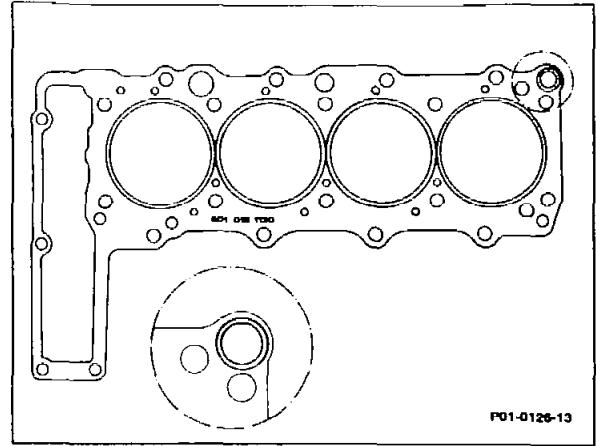

Combustion chamber recess

The size of the combustion chamber recess (d) was increased to reduce the thermal load in the cylinder head. Production breakpoint 06/88.

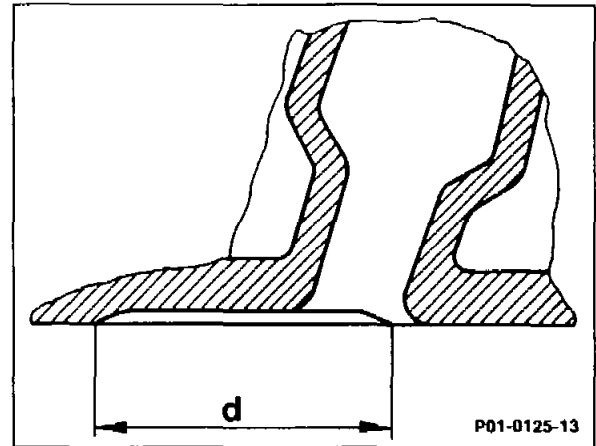

Reinforcement on valve tappet guides and exhaust passages

As of 05/89 the supports at the valve tappet guides and exhaust passages have been reinforced.

Modified cylinder heads can be recognized by the cast number on the intake side.

Engine	previous cast no.	new cast no.
601	601 016 07 01	601 016 10 01

B. Engine 602, 603

Differentiation of cylinder heads for naturally aspirated and turbo-engines

The cylinder heads for turbo-engines 602.96, 603.96 and 603.97 are reinforced at the water jacket due to the higher combustion pressures.

On turbo-engines the diameter (d) of the pre-combustion chamber bore is 15 mm, on naturally aspirated engines 14 mm.

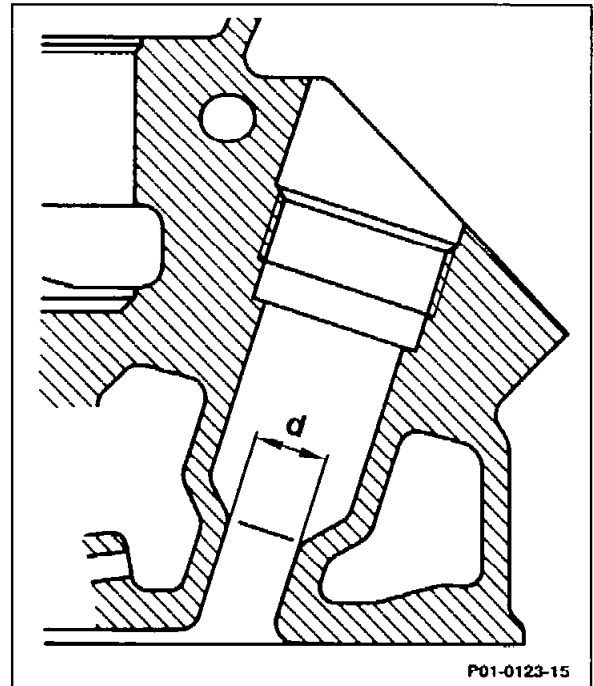

The cylinder heads on turbo-engines are provided with an identification strip. This identification strip (arrow) is located on the parting surface for the cylinder head cover at the front right.



Do not mix up cylinder heads for turbo-engines and naturally aspirated engines.

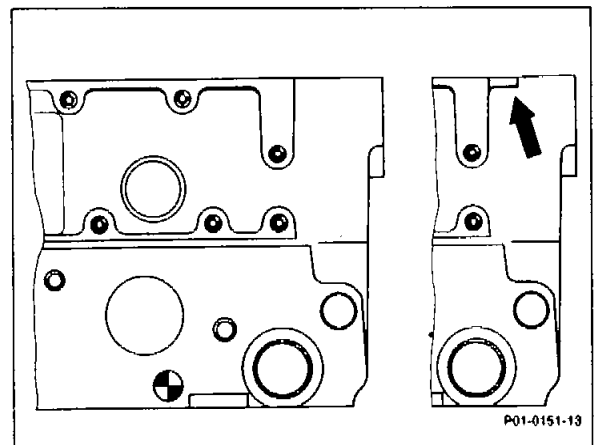

The cylinder head gasket for the turbo-engines has stainless steel inserts around the combustion chambers (arrow).

The combustion chamber inserts on the standard gaskets installed on naturally aspirated engines consist of normal sheet steel.

Only the cylinder head gaskets with stainless steel inserts are available as replacement parts for both the naturally aspirated and turbo-engines.

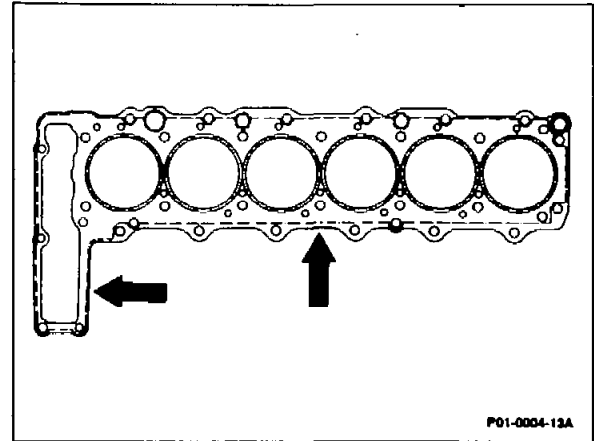

Cylinder head gasket with Viton sealing ring

Since 03/87 a Viton sealing ring is inserted at the rear oil return passage to prevent oil leakage.

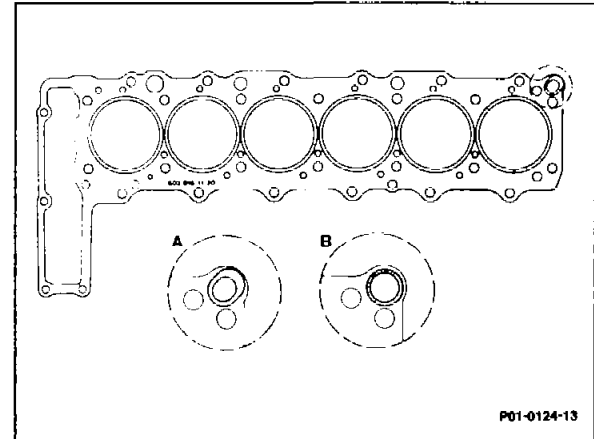

- A 1st version with sheet metal jacket
- B 2nd version with Viton sealing ring

Modifications In area of timing chain case

Since 09/87 on engine 602.91 and since 10/87 on engine 603.91 for production reasons the height of the bridge in the cylinder head in the area of the timing chain case was increased to 32 mm (previously 12 mm).

This modification made it necessary to change the dimensions of the two cylinder head bolts (arrow). The new bolt length is M 8 × 50 (previously M 8 × 30).

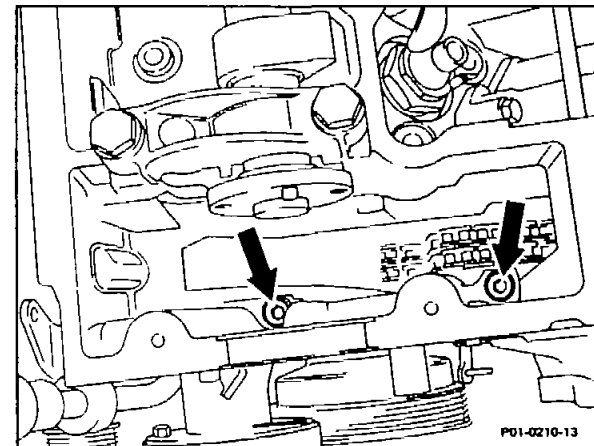

Production change for protection against cracks in water jacket

Since 10/87 the bolt flutes on the exhaust side have been reinforced and the recesses (hollows) between the coolant ducts on the outlet side filled to prevent cracks in the cylinder head water jacket.

The baseplate on the intake side was reinforced from previously 11 mm to 14 mm.

Cylinder head gasket for improved sealing

The cylinder head gasket has been equipped with circumferential silicone sealing strips (arrow) on both sides and a Viton sealing ring at the oil return passage at the rear right to better prevent water and oil leakage.

Production breakpoint

Engine 603.960/963	10/88
Engine 602.961/962	05/89
Engines 602.91, 603.91	09/89

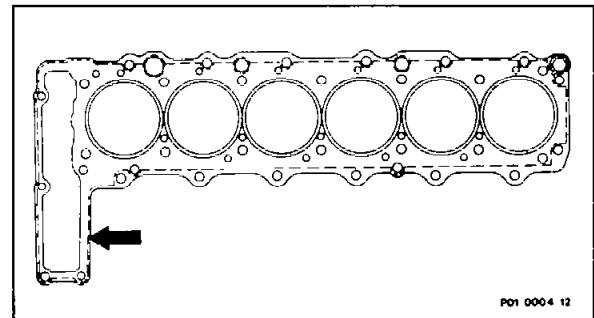

Cylinder head gasket, engines 602, 603 (except for engine 603.970)

The combustion chamber insert (dotted line) has been modified at the 1st cylinder on the cylinder block side as of 01/90.

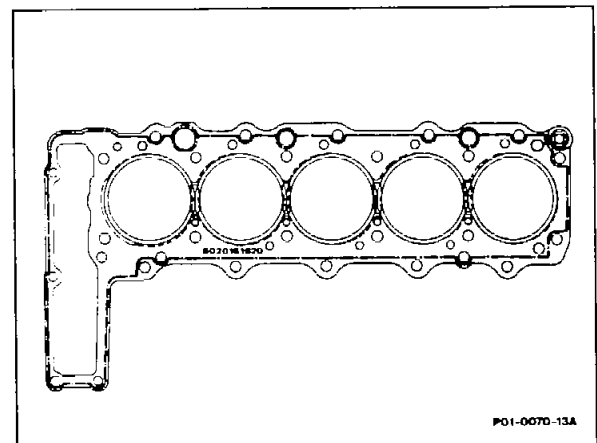

Cylinder head gasket, engine 603.970

As of 01/90 combustion chamber insert modified Silicone sealing strip position changed on both sides.

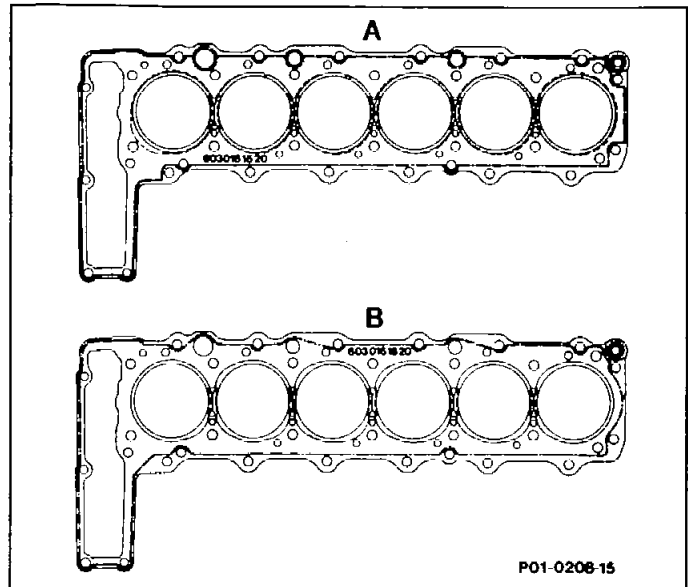

- A. 1st version (Götze)
- B. 2nd version (Elring)

Improvement to passage supports in water jacket

As of 12/88 the passage supports in the cylinder head water jacket were improved on the turbo-engines.

Reinforcements at valve tappet guides and exhaust passages

The reinforcements at the valve tappet guides and exhaust passages have been reinforced. Modified cylinder heads can be recognized by the cast no. on the intake side, see table.

Engine	previous cast no.	new cast no.	Production breakpoint
602	602 016 03 01	602 016 07 01	09/89
602 Turbo	602 016 06 01	602 016 08 01	07/89
603	603 016 10 01	603 016 16 01	10/89
603 Turbo	603 016 15 01	603 016 17 01	07/89

Cylinder head gasket engine 603.971

Since 11/92 with 6 holes (arrows) in the web area.

Improved gas seal at contact point to timing case cover (shaded area).

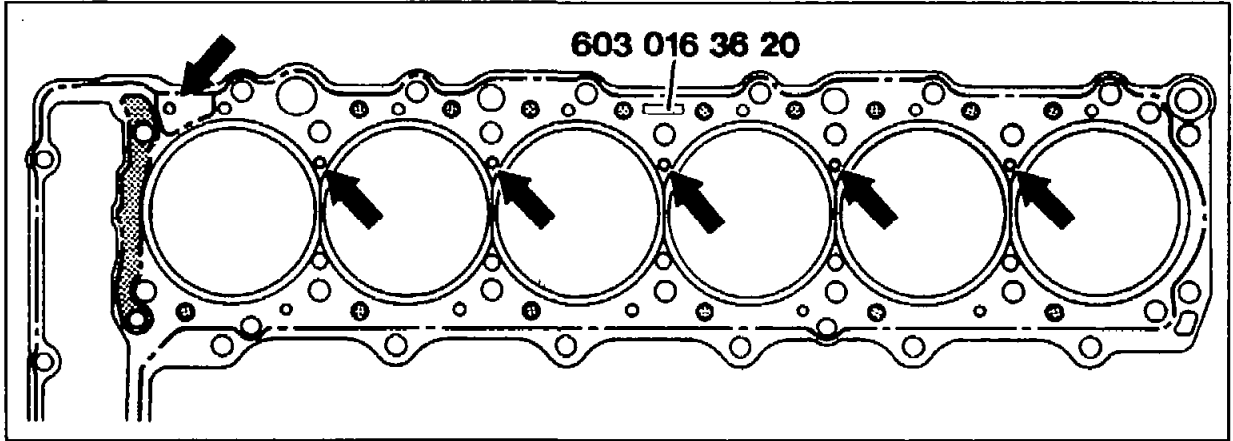

P01-5760-53