

01-222 Removal and installation of end cap

Preceding work:
Transmission removed (26-020 or 27-600).
Flywheel removed (03-410).

Operation no. of the operation texts and work units or standard texts and flat rates
01-8913

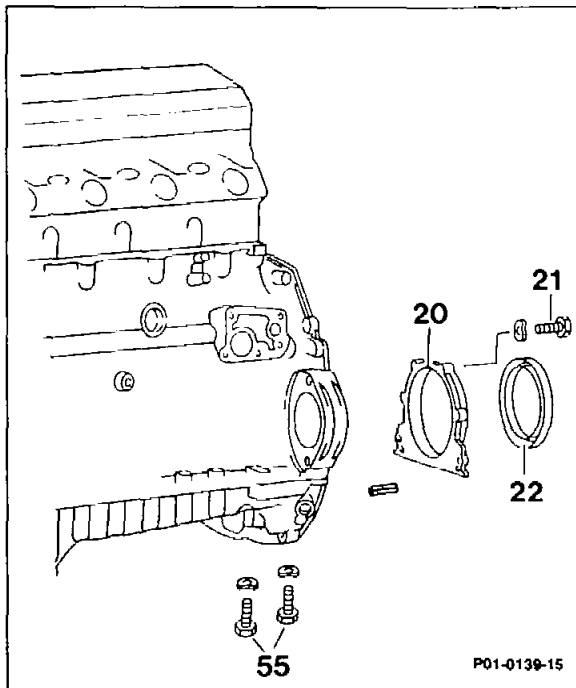

If the end cap is removed because of a leakage or if the leakage cannot be properly located, the leakage can be made visible by spraying with MB-Contrast-Spray 000 989 03 59 (see PR 0.10/1).

Hex. head bolts (55)	in oil pan, screw out, screw in, 25 Nm (step 1).
Hex. head bolts (21)	Hex. head bolts (21) in end cap (20), screw out, screw in, 10 Nm (step 2).

Note

Coat threads of hex. head bolts with sealant 002 989 20 10.

End cap (20) press out together with crankshaft radial seal (22), press in, installation sleeve 601 589 03 43 00 (step 3).



Pay attention to oil pan gasket. Avoid damaging.

Note

Clean gasket residues off of parting surface on end cap and coat parting surface of cap with sealant 002 989 00 20 10. Check crankshaft radial seal and remove if required, install, installation sleeve 601 589 03 43 00.

Sealant

Omnifit	002 989 00 20 10
---------	------------------

Tightening torques

	Nm
Hex. head bolts, end cap	10
Hex. head bolts, oil pan	25

Special tools

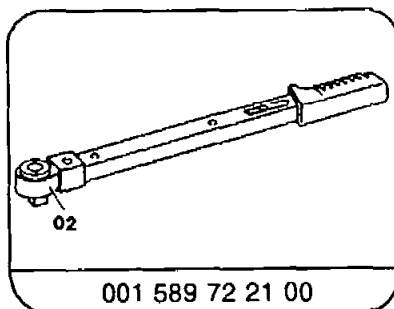
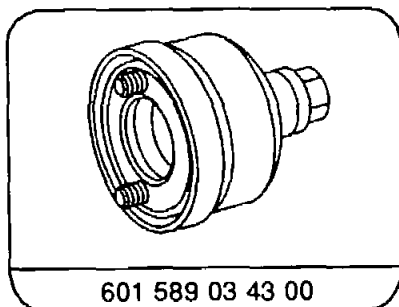

Note

Since 09/94 an end cover with integrated shaft seal (version B) has been installed on engines 601, 602, 603. End cover and shaft seal are a unit; the shaft seal is vulcanized in the cover.



When performing repairs, install the previous version of radial shaft seal and end cover.

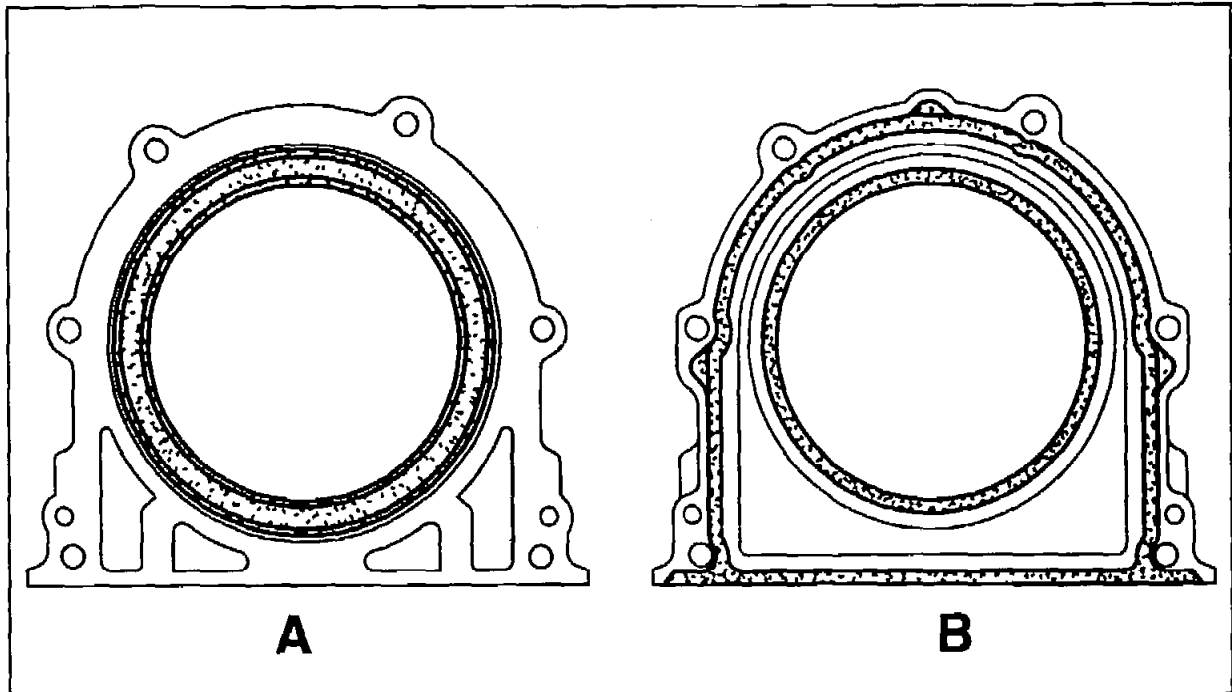

P03.00-0215-55

Removal, installation

1 Screw out the two hex. head bolts (55) in the oil pan.

Installation note

Tightening torque 25 Nm.

2 Screw out hex. head bolts (21) in end cap (20).

Installation note

Coat threads on hex. head bolts with sealant 002 989 00 20 10.

Tightening torque 10 Nm.

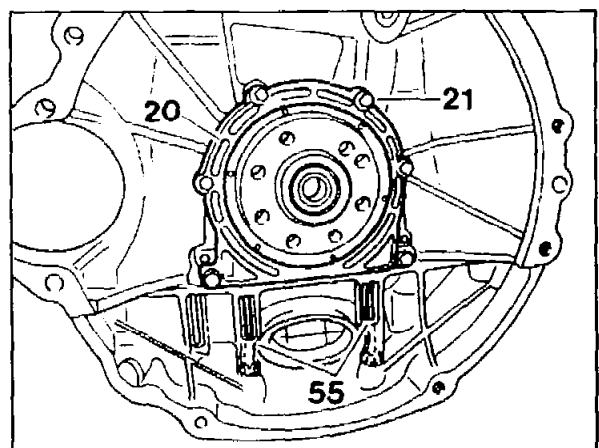

P01-2462-13

3 Press end cap off of crankcase at tabs (arrows) and remove crankshaft radial seal from crankshaft journal.



When pressing the end cap on and off pay attention to the oil pan gasket. Avoid damaging.

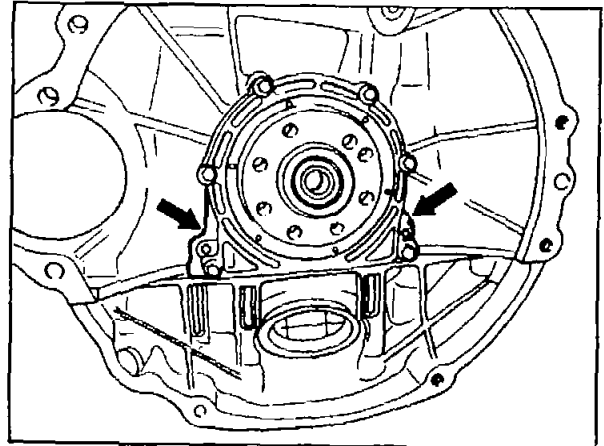

P01-2463-13

Installation note

Clean gasket residues off of parting surface on end cap. Check crankshaft radial seal and replace if required. Coat parting surface on end cap with sealant 002 989 00 20 10 and slide end cap together with radial seal over attached installation sleeve 601 589 03 43 00.

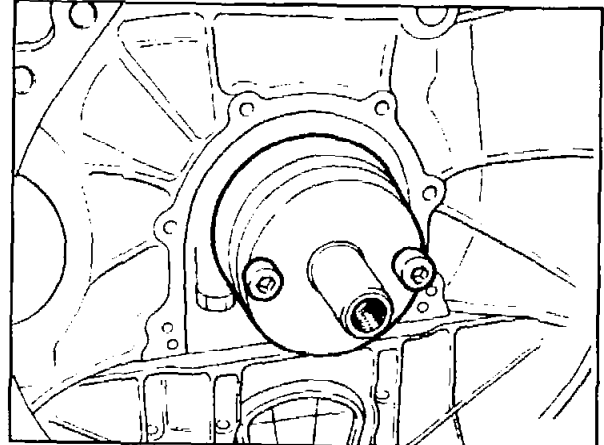

P03-2143-13