

03-4620 Removing and installing two-mass flywheel

Preceding work:
 Manual transmission removed (26-020).
 Clutch removed (25-050).
 Retaining lock for crankshaft/ring gear installed (03-5000).

Operation no. of operation texts and work units or standard texts
 and flat rates
 03-8001, 03-8201

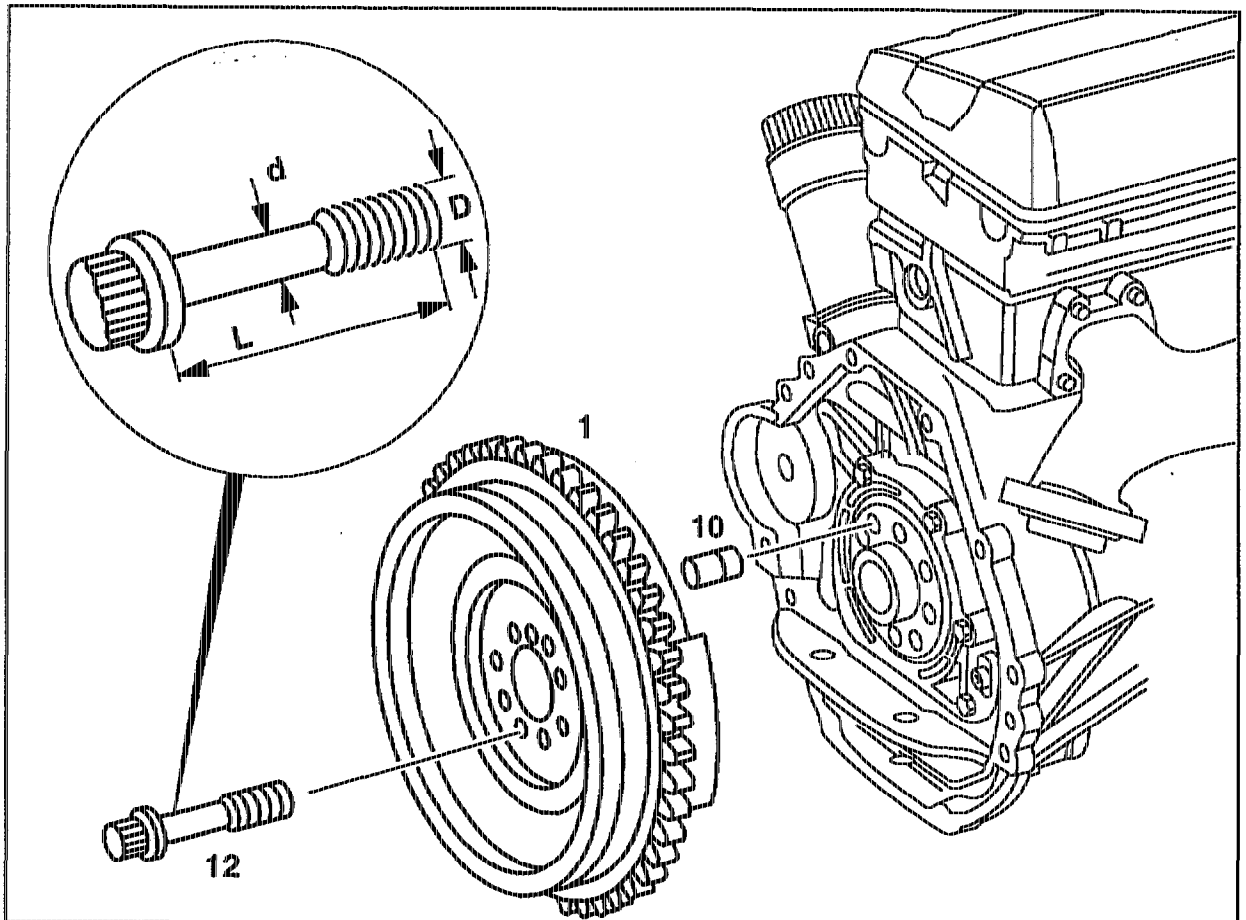

P03-5286-57

Stretch bolts (12) (1st version) or straight
 stretch shank bolts (2nd version) or torx bolts
 (with sheet steel two-mass flywheel)

unscrew, screw on.

Stretch bolts (12)

inspect, see table.

Note

If the shank \varnothing is less than the minimum \varnothing (d),
 replace stretch bolt (12).

Straight stretch shank bolts or torx bolts

replace, see note.

Two-mass flywheel (1) or sheet steel two-mass
 flywheel

remove, install.

Note

The installation position of the flywheel (1) is
 determined by the dowel pin (10).

Stretch shank bolt (1st version)

Thread	D		M10 × 1
Stretch shank Ø	d	when new	8.5-0.2
		minimum Ø	8.1
Bolt length	L	when new	57 ± 0.2
Part no.			103 032 00 71

Tightening torque 30 Nm + 90° tightening angle

1) Thread and bolt head contact surface moistened with assembly oil

Straight stretch shank bolt (2nd version)

Thread	D		M10 × 1
Bolt length	L		57 ± 0.2
Part no.			111 032 00 71

Tightening torque 45 Nm + 90° tightening angle

1) Thread and bolt head contact surface moistened with assembly oil

Torx bolt (with sheet steel two-mass flywheel as of 05/1995)

Thread	D		M10 × 1
Bolt length	L		28.5 ± 0.2

Tightening torque 1) 45 Nm + 90° tightening angle

1) Thread and bolt head contact surface moistened with assembly oil

Note

The straight stretch shank bolt should be replaced when performing repairs; it must be used only once.

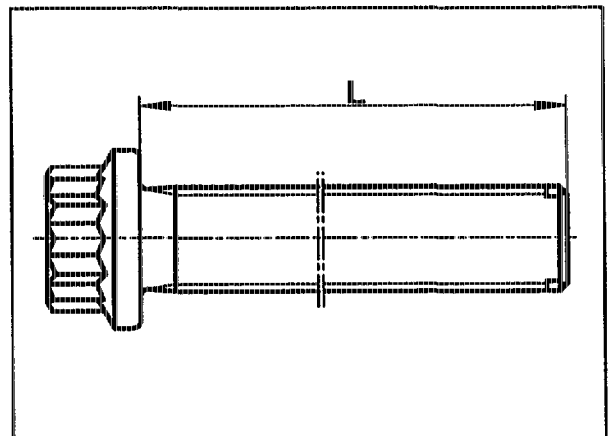

P03-5365-13

As of May 1995 the bolts of the driven plate and two-mass flywheel (sheet steel two-mass flywheel) have been standardized. The torx bolt (3rd version) should be replaced when performing repairs.

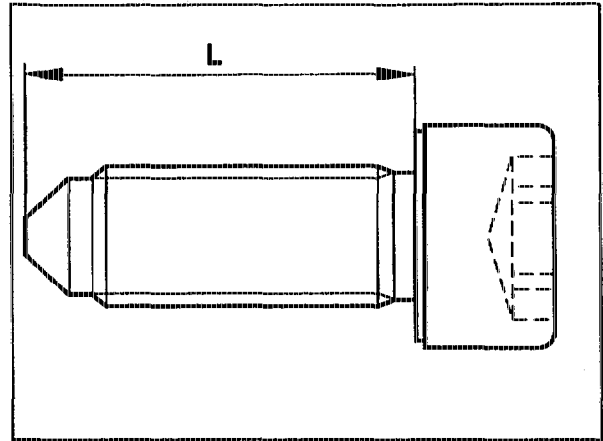

P03.30-0233-13

Special tools

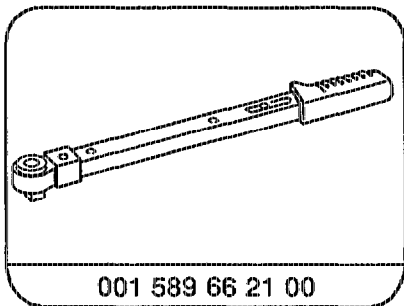

001 589 66 21 00

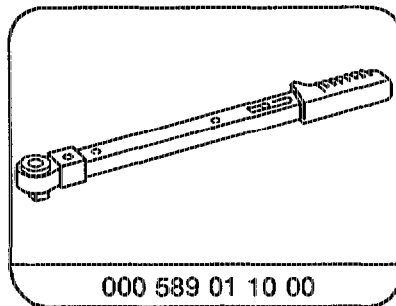

000 589 01 10 00

Note

If no tightening angle torque wrench is available, the stretch shank bolts or straight stretch shank bolts can be torqued further to the specified angle in a single operation with a wrench socket and tommy bar. A flexi-rod torque wrench must not be used for tightening to tightening angles in order to avoid any angle errors. For design of two-mass flywheel see "Function of two-mass flywheel (03-4600)".

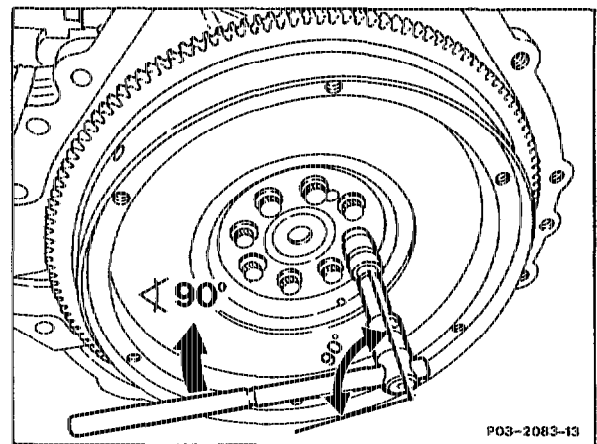

P03-2083-13