

14-7611 Testing exhaust gas recirculation

Operation no. of operation texts and work units or standard texts and flat rates:
14-7611

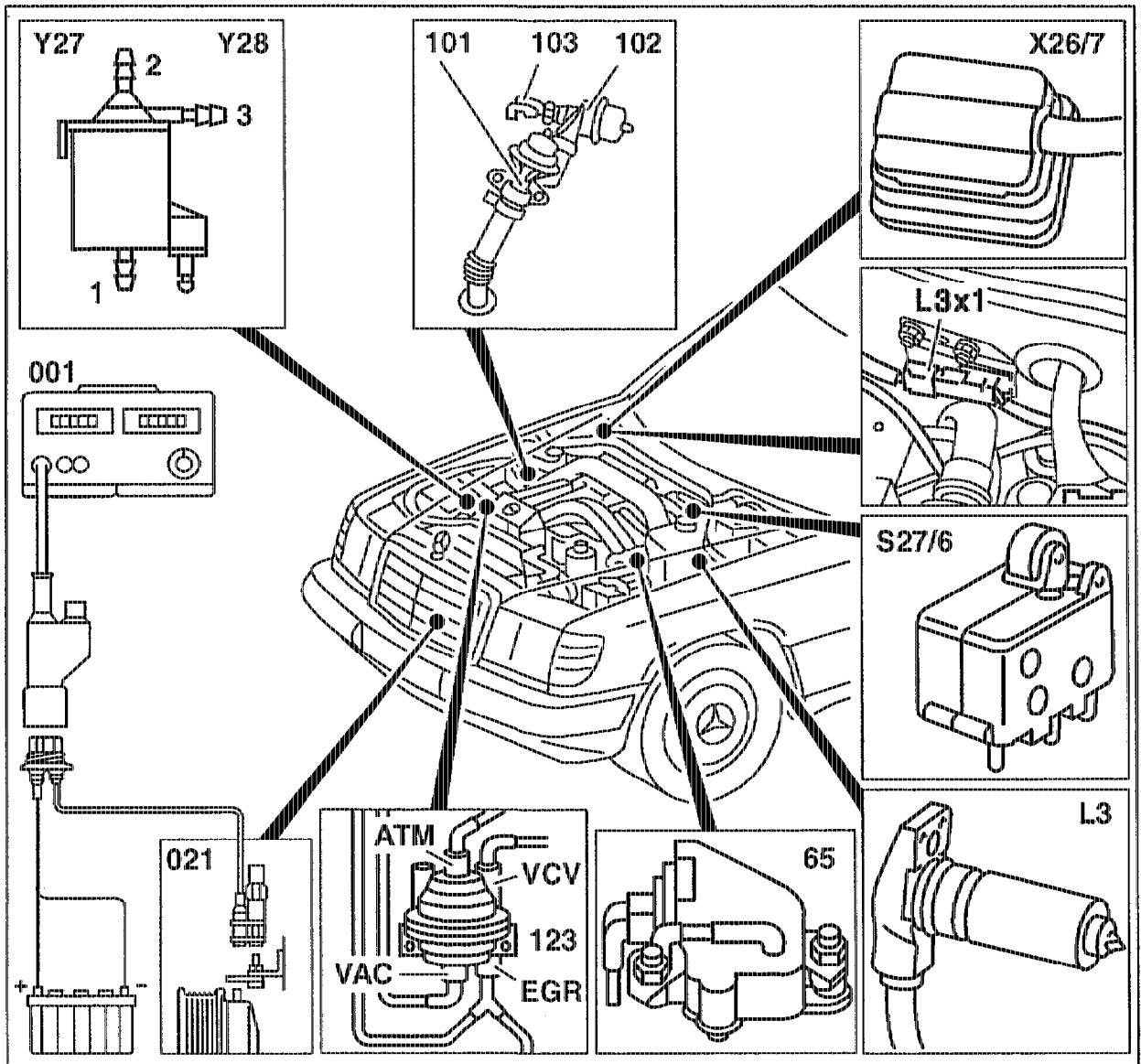

P14-5141-59

Connection diagram of digital tester without adapter, location of components

- Digital tester (001) and pulse generator (021) connect, disconnect.
- Battery voltage test, approx. 12 V. Measured at overvoltage protection between contacts 1 and 5.
- Engine to coolant temperature of 65 – 80 °C ... warm up.

Function test perform. Engine 605.911 section "a"
 Engine 606.910 section "b"
 If no fault is found, perform appropriate component test in accordance with test program.

Special tools

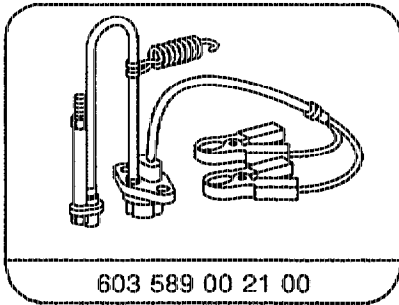

603 589 00 21 00

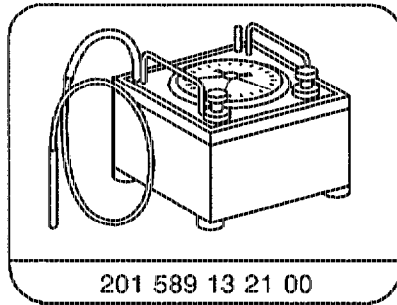

201 589 13 21 00

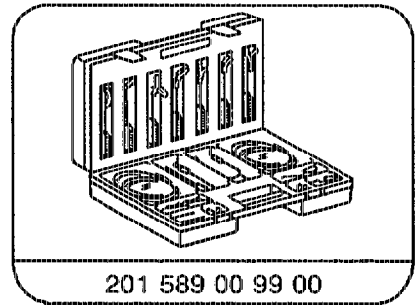

201 589 00 99 00

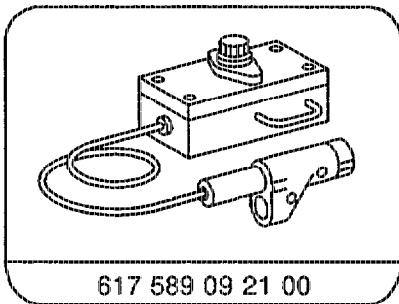

617 589 09 21 00

Commercially available tools and testers (see Workshop Equipment Manual)

Designation	e. g. make, order no.
Multimeter	Sun, DMM-5 Fluke 23 DB, 83, 88 ITT Metrix MX 47, 50, 51, 52
Use without adapter	
Digital tester	AVL, Diesel-Tester 873 Bosch, ETD 019.02 Sun, DIT 9100
Use with adapter	
Digital tester Engine diagnostics tester	Bosch, MOT 103, 002.02, 150, 250, 401 Hermann D960, D980 Bear DEACE
Y distributor	MB part no. 117 078 01 45

a. Engine 605.911

Function diagram of exhaust gas recirculation, engine M 605.911 with manual transmission

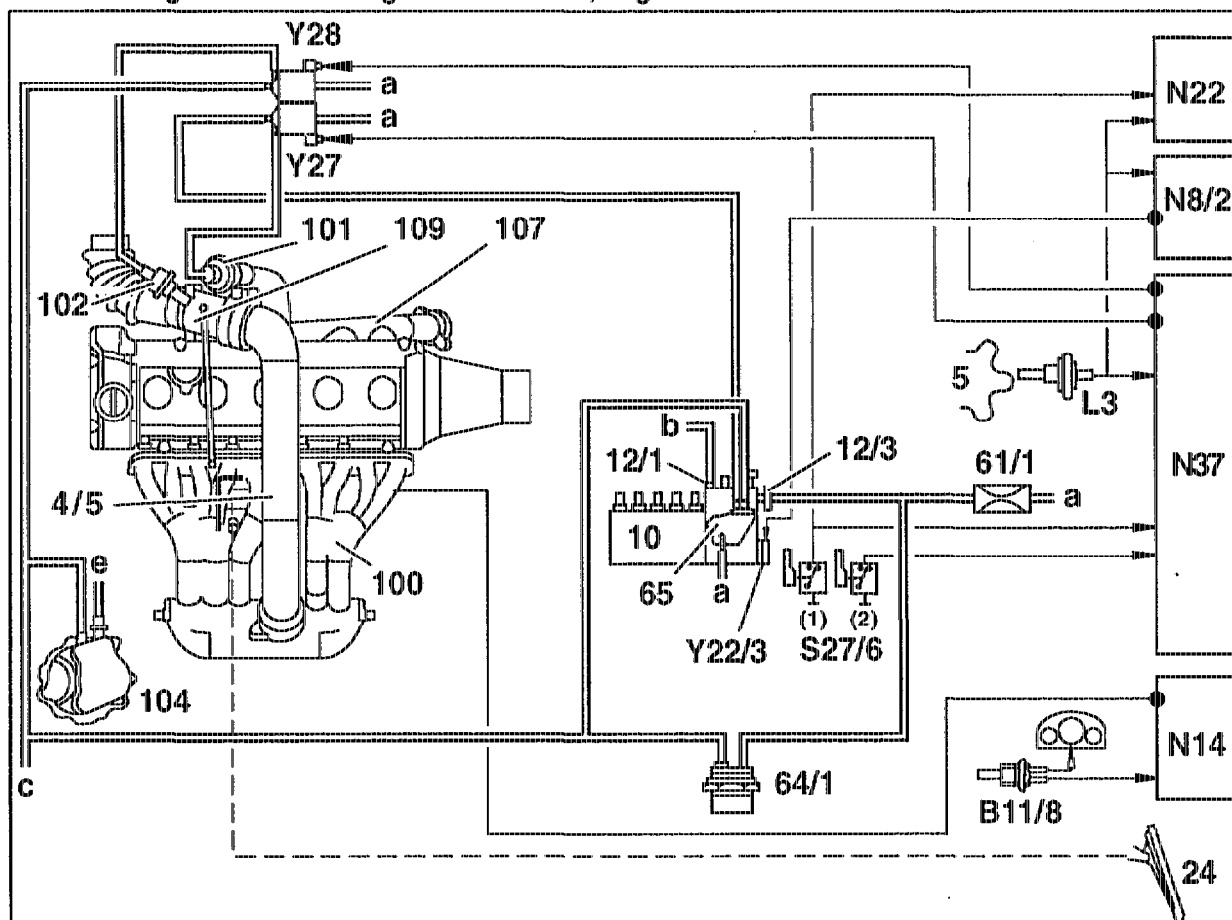

P14-5139-57

4/5	Air cleaner cross pipe	B11/8	Coolant temperature sensor, afterglow
5	Flywheel	L3	Starter ring gear speed sensor
10	In-line injection pump	N8/2	Anti-jerk control (ARA) control unit
12/1	Stop vacuum unit	N14	Preglow time relay
12/3	Atmospheric pressure-dependent full-load stop (PLA) vacuum unit	N22	Automatic climate control (KLA) pushbutton control unit
24	Accelerator pedal	N37	Exhaust gas recirculation (ARF) control unit
61/1	Restriction with filter	S27/6	AC compressor cutoff/ARF microswitch
64/1	Thermo valve, closes 30 °C	Y22/3	ARA actuator
65	Vacuum control valve	Y27	ARF switchover valve
100	Intake manifold	Y28	Vacuum control flap switchover valve
101	Exhaust gas recirculation valve		
102	Vacuum control flap vacuum unit	a	Air admission to vehicle interior
104	Vacuum pump	b	Key-operated stop
107	Exhaust manifold	c	Other consumers
109	Vacuum control flap housing	e	To brake servo unit

Function diagram of exhaust gas recirculation, engine M 605.911 with automatic transmission

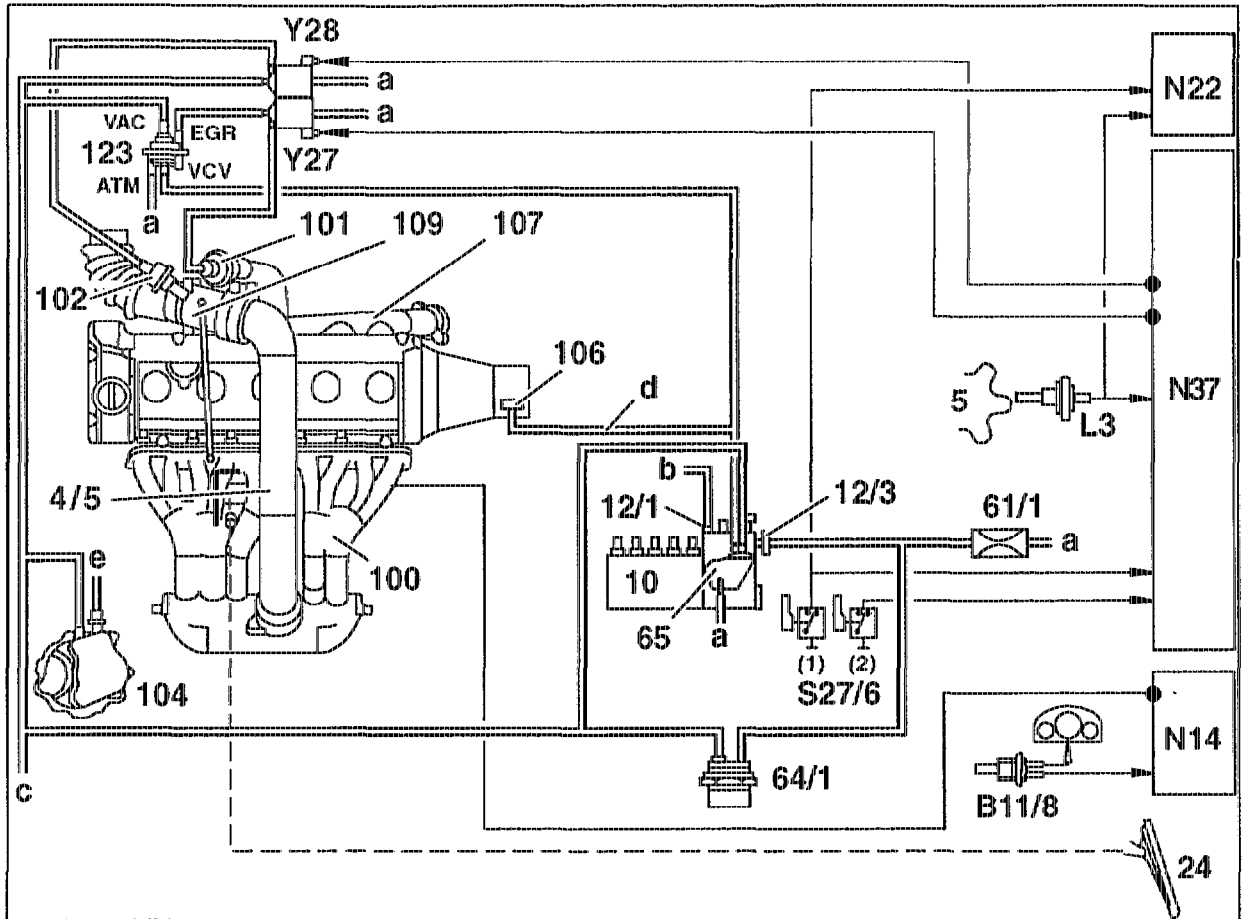

P14-5140-57

4/5	Air cleaner cross pipe	B11/8	Coolant temperature sensor, afterglow
5	Flywheel	L3	Starter ring gear speed sensor
10	In-line injection pump	N14	Preglow time relay
12/1	Stop vacuum unit	N22	Automatic climate control (KLA) pushbutton control unit
12/3	Atmospheric pressure-dependent full-load stop (PLA) vacuum unit	N37	Exhaust gas recirculation (ARF) control unit
24	Accelerator pedal	S27/6	AC compressor cutoff/ARF microswitch
61/1	Restriction with filter	Y27	ARF switchover valve
64/1	Thermo valve, closes 30 °C	Y28	Vacuum control flap switchover valve
65	Vacuum control valve		
100	Intake manifold	a	Air admission to vehicle interior
101	Exhaust gas recirculation valve	b	Key-operated engine stop
102	Vacuum control flap vacuum unit	c	Other consumers
104	Vacuum pump	d	To modulating pressure vacuum unit
106	Modulating pressure vacuum unit	e	To brake servo unit
107	Exhaust manifold		
109	Vacuum control flap housing		
123	Vacuum amplifier		
			Pressure and vacuum connections at vacuum amplifier
		ATM	Air admission to vehicle interior
		EGR	Vacuum to ARF switchover valve
		VAC	Vacuum from vacuum pump
		VCV	Vacuum from vacuum control valve

Note

Actuation of the ARF valve or of the vacuum control flap by the ARF control unit (N37) is performed:

This operating delay exists after each engine start irrespective of coolant temperature.

- Exhaust gas recirculation, from approx. 100 seconds after engine start
- Vacuum control flap, from approx. 150 seconds after engine start

Function test

Test step/ Test scope	Tester/ Test connection	Operation/ Requirement	Specification	Possible cause/ Remedy
ARF valve	Connect vacuum tester directly to ARF valve	Engine off Pressurize ARF valve with 400 mbar. Detach vacuum line.	ARF valve closes audibly	Replace ARF valve
Vacuum control flap	Connect vacuum tester directly to vacuum unit of vacuum control flap	Engine off Pressurize vacuum unit with 400 mbar. Detach vacuum line.	Vacuum control flap moves back automatically	Check vacuum control valve housing
Emissions control loop	Connect vacuum tester to ARF valve with Y distributor	Engine at 1250 ± 50 rpm	360 ± 20 mbar	ARF control unit (N37) Vacuum control valve (65)
		Engine at 3400 ± 50 rpm	< 10 mbar	Vacuum amplifier (123) 1) ARF switchover valve (Y27) Vacuum supply
	Connect vacuum tester to vacuum unit of vacuum control flap with Y distributor	Engine at 1300 ± 50 rpm	> 700 mbar	ARF control unit (N37) Vacuum control flap switchover valve (Y28)
		3400 ± 50 rpm	< 10 mbar	Vacuum supply



1) Only with automatic transmission

Test program components test

Test step/ Test scope	Tester/ Test connection	Operation/ Requirement	Specification	Possible cause/ Remedy
1) Vacuum amplifier (123) and vacuum setting	Connect vacuum tester to the EGR connection of vacuum amplifier with Y distributor.	Engine at 1250 ± 50 rpm	360 ± 20mbar Setting: 360 ± 5mbar	If vacuum is above or below specification, adjust vacuum. To do this, pull off protective cap and adjust to specified setting with wrench socket insert (4 mm). Vacuum control valve Test supply pressure at "VAC" connection, replace vacuum amplifier if necessary. Test vacuum line according to function diagram. Test supply pressure at vacuum pump (R1 Engine 601, 602.91, 603.91, Combustion I, 07.1-160). Specification: > 700 mbar.
Vacuum control valve (65)	a) automatic transmission Connect vacuum tester to the "VCV" connection of vacuum amplifier (123) with Y distributor. b) manual transmission Connect vacuum tester to connection 2 of switchover valve (Y27) with Y distributor (head connection vertical).	Engine idling Engine off, accelerator control to full load position Engine idling Engine off, accelerator control to full load position	> 350 mbar < 10mbar > 300mbar < 10mbar	Test vacuum lines according to function diagram Test supply pressure Specification > 700 mbar

1) Only with automatic transmission

Test program component test

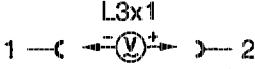
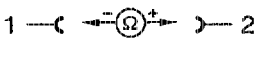
Test step/ Test scope	Tester/ Test connection	Operation/ Requirement	Specification	Possible cause/ Remedy
Switchover valves (Y27, Y28) Test voltage supply	 	Engine at 1250 ± 50 rpm	11–14 V	ARF control unit (N37)
		3400 ± 50 rpm	< 1 V	Starter ring gear speed sensor (L3)
ARF switchover valve (Y27) Test vacuum supply	Connect vacuum tester to connection 3 of ARF switchover valve with Y distributor.	Engine at 1250 ± 50 rpm	> 300 mbar	Vacuum control valve (65)
				Vacuum amplifier (123) ¹⁾
Vacuum control flap switchover valve (Y28) Test vacuum supply	Connect vacuum tester to connection 3 of vacuum control flap switchover valve with Y distributor.	Engine at 1300 ± 50 rpm	> 700 mbar	Test supply vacuum
Starter ring gear speed sensor (L3) Voltage		Starter ring gear plug connection (L3x1) disconnected		(L3), clearance, dirt
		Engine idling	> 10V ~ ²⁾	Open circuit in wiring
Resistance		Engine off	Beru: 530 Ω ³⁾ ± 10 % VDO: 1900 Ω ³⁾ ± 10 % AB-Elektronik 1040 Ω ³⁾ ± 10 %	(L3), clearance, dirt Open circuit in wiring

1) Only with automatic transmission

2) Voltage rises as engine speed increases

3) Measured at ambient temperature of 20 °C (each 10 °C change in ambient temperature alters resistance by 4 %)

Test program components test

Test step/ Test scope	Tester/ Test connection	Operation/ Requirement	Specification	Possible cause/ Remedy
Microswitch (S27/6)	<p style="text-align: center;">X26/7</p> <p>5 ——— ←⊖→ ——— 2 6 ——— ←⊖→ ——— 2</p>	<p>Engine off</p> <p>For both test connections: Accelerator pedal in idle position Accelerator pedal in full load position</p>	<p>< 1 Ω</p> <p>∞ Ω</p>	<p>(S27/6)</p> <p>Wiring</p>
AC compressor cutoff	<p style="text-align: center;">X26/7</p> <p>9 ——— ←⊖→ ——— 2</p>	<p>Engine off</p> <p>Accelerator pedal in idle position Accelerator pedal in full load position</p>	<p>∞ Ω</p> <p>< 1 Ω</p>	<p>(S27/6)</p> <p>Wiring</p>

b. Engine 606.910

Function diagram of emissions control, engine M 606.910 with manual transmission

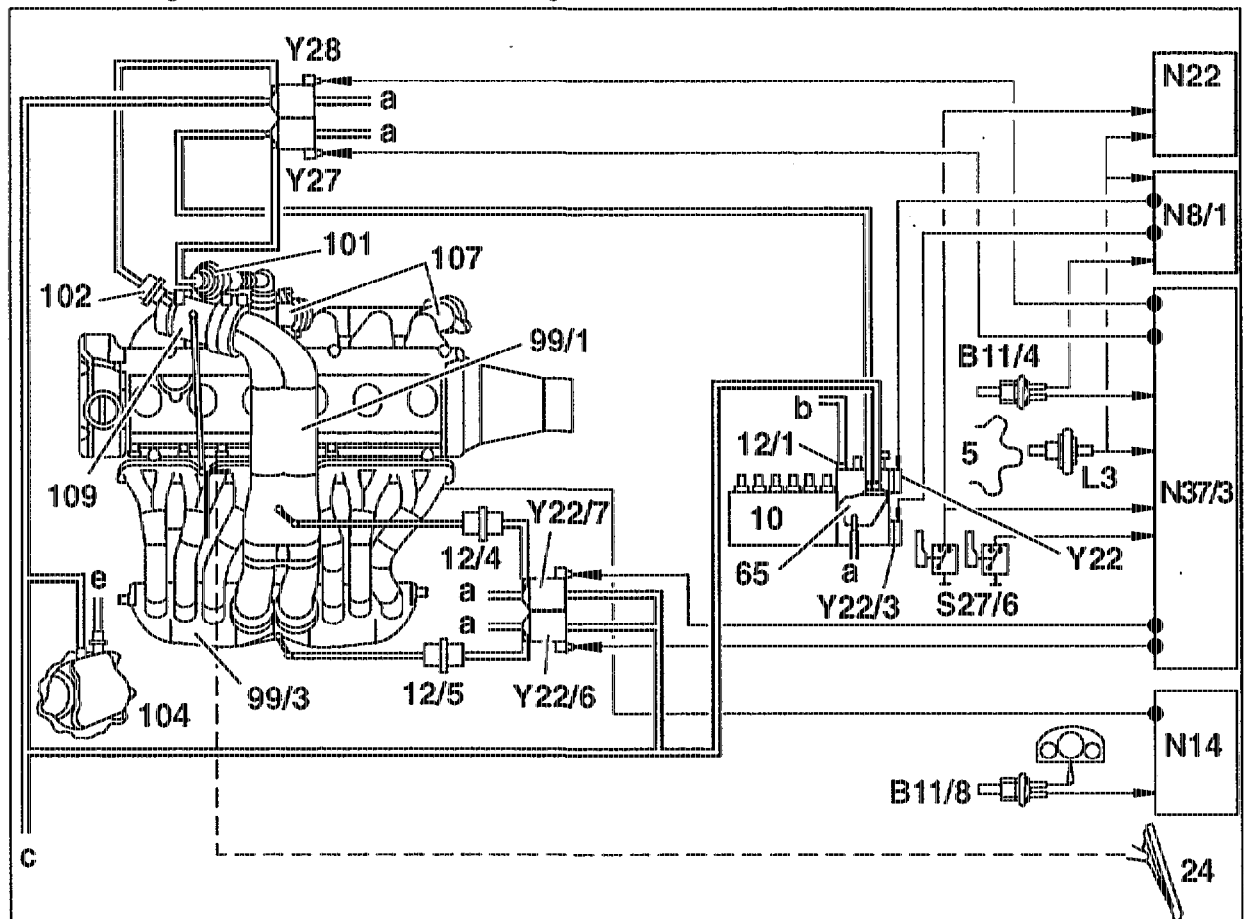

P14-5148-57

5	Flywheel	B11/4	Coolant temperature sensor
10	In-line injection pump	B11/8	Coolant temperature sensor, afterglow
12/1	Stop vacuum unit	L3	Speed sensor
12/4	Resonance intake line vacuum unit	N8/1	ELR/ARA control unit
12/5	Resonance intake manifold vacuum unit	N14	Preglow time relay
24	Accelerator pedal	N22	Automatic climate control (KLA) pushbutton control unit
65	Vacuum control valve	N37/3	ARF/variable intake manifold system control unit
99/1	Resonance intake line	S27/6	AC compressor cutoff/ARF microswitch
99/3	Resonance intake manifold	Y22	ELR actuator
101	Exhaust gas recirculation valve	Y22/3	ARA actuator
102	Vacuum control flap vacuum unit	Y22/6	Resonance intake manifold switchover valve
104	Vacuum pump	Y22/7	Resonance intake line switchover valve
107	Exhaust manifold	Y27	ARF switchover valve
109	Vacuum control flap housing	Y28	Vacuum control flap switchover valve
		a	Air admission
		b	Key-operated engine stop
		c	Other consumers
		e	To brake servo unit

Function diagram of emissions control, engine M 606.910 with automatic transmission

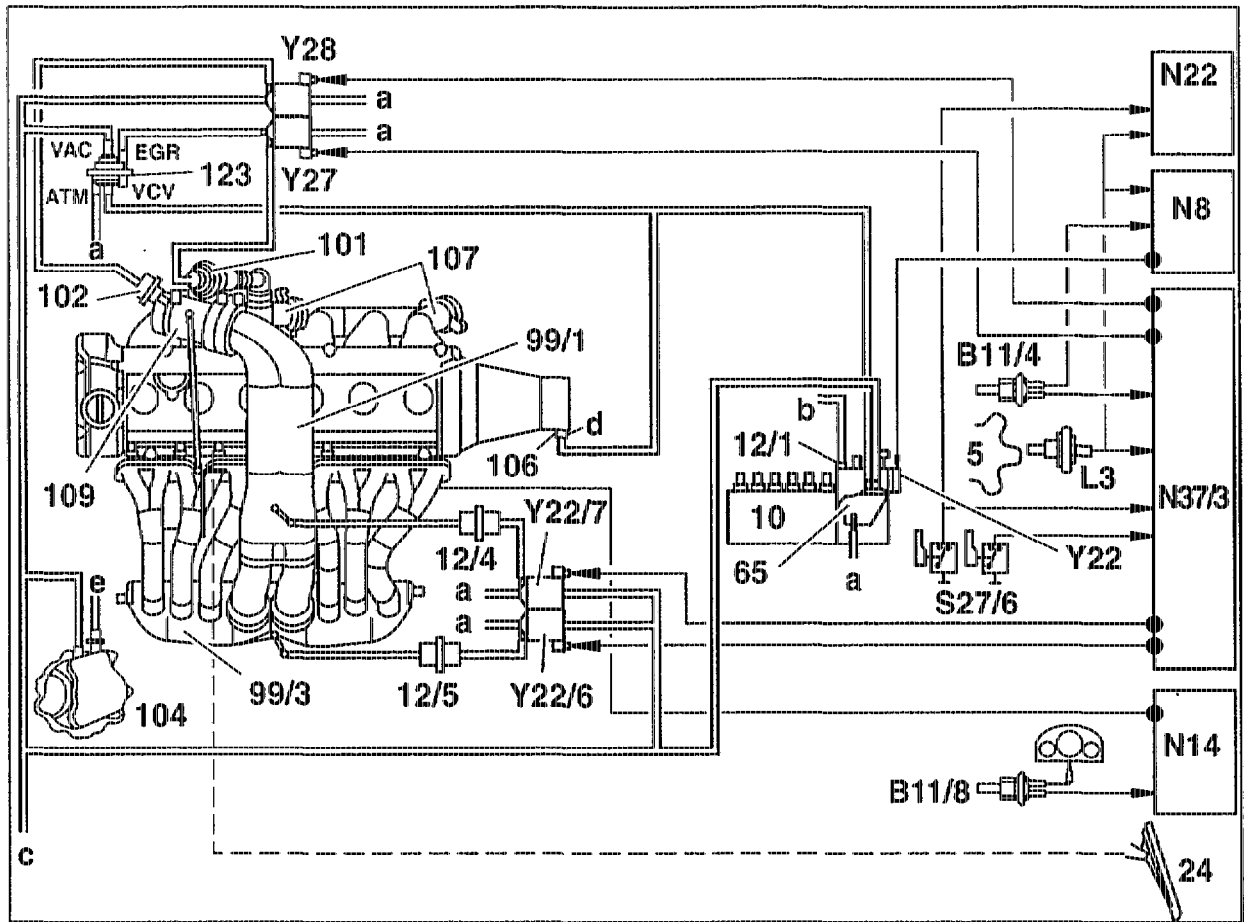

P14-5149-57

- | | | | |
|------|---------------------------------------|-------|--|
| 5 | Flywheel | B11/4 | Coolant temperature sensor |
| 10 | In-line injection pump | B11/8 | Coolant temperature sensor, afterglow |
| 12/1 | Stop vacuum unit | L3 | Speed sensor |
| 12/4 | Resonance intake line vacuum unit | N8 | Electronic idle speed control (ELR) control unit |
| 12/5 | Resonance intake manifold vacuum unit | N14 | Preglow time relay |
| 24 | Accelerator pedal | N22 | Automatic climate control (KLA) pushbutton control unit |
| 65 | Vacuum control valve | N37/3 | ARF/variable intake manifold system control unit |
| 99/1 | Resonance intake line | S27/6 | AC compressor cutoff/ARF microswitch |
| 99/3 | Resonance intake manifold | Y22 | Electronic idle speed control (ELR) actuator |
| 101 | Exhaust gas recirculation valve | Y22/6 | Resonance intake manifold switchover valve |
| 102 | Vacuum control flap vacuum unit | Y22/7 | Resonance intake line switchover valve |
| 104 | Vacuum pump | Y27 | Exhaust gas recirculation (ARF) switchover valve |
| 106 | Modulating pressure vacuum unit | Y28 | Vacuum control flap switchover valve |
| 107 | Exhaust manifold | | |
| 109 | Vacuum control flap housing | | |
| 123 | Vacuum amplifier | | |
| | | a | Air admission |
| | | b | Key-operated engine stop |
| | | c | Other consumers |
| | | d | To vacuum unit, automatic transmission |
| | | e | To brake servo unit |
| | | | Pressure and vacuum connections at vacuum amplifier |
| | | ATM | Air admission to vehicle interior |
| | | EGR | Vacuum to ARF switchover valve |
| | | VAC | Vacuum from vacuum pump |
| | | VCV | Vacuum from vacuum control valve |

Test conditions

Coolant temperature 65–80° C, coolant temperature sensor (B11/4) operating properly.

Note

The components are operated by the ARF/variable intake manifold system control unit (N37/3) subject to the following conditions:

- from approx. 30 s after each engine start
- exhaust gas recirculation from approx. 50 °C coolant temperature
- vacuum control flap from approx. 65 °C coolant temperature

The operation delay exists after each engine start even if the coolant temperature is already greater than 65 °C when the engine is started.

Function test

Test step/ Test scope	Tester/ Test connection	Operation/ Requirement	Specification	Possible cause/Remedy
ARF valve	Connect vacuum tester directly to ARF valve	Engine off Pressurize ARF valve with 400 mbar Detach vacuum line	ARF valve closes audibly	Replace ARF valve
Vacuum control flap	Connect vacuum tester directly to vacuum unit of vacuum control flap	Engine off Pressurize vacuum unit with 400 mbar. Detach vacuum line	Vacuum control flap moves back automatically	Check vacuum control flap housing
Emissions control loop	Connect vacuum tester to ARF valve with Y distributor	Engine at 1100 ± 50 rpm 3200 ± 50 rpm as of approx. 10/93: 2850 ± 50 rpm	375 ± 15 mbar 325 ± 15 mbar (USA) < 10 mbar	ARF/variable intake manifold system control unit (N37/3) ARF switchover valve (Y27) Vacuum control valve (65) Vacuum amplifier (123) 1) Vacuum supply
	Connect vacuum tester to vacuum unit of vacuum control flap with Y distributor	Engine at 1250 ± 50 rpm 2550 ± 50 rpm	> 700 mbar < 10 mbar	ARF/variable intake manifold system control unit (N37/3) Vacuum control flap switchover valve (Y28) Vacuum supply Altitude sensor B18 only (USA)



1) Only with automatic transmission

Test program components test

Test step/ Test scope	Tester/ Test connection	Operation/ Requirement	Specification	Possible cause/ Remedy
Vacuum amplifier (123) ¹⁾ and vacuum setting	Connect vacuum tester to inlet 2 of switchover valve (Y27) with Y distributor	Engine idling	375 ± 15 mbar 335 ± 15 mbar (USA) Setting: 375 ± 5 mbar 335 ± 5 mbar (USA)	If vacuum is above or below specification, adjust vacuum. To do this, pull off protective cap and adjust to specified setting with socket wrench insert (4 mm). Vacuum control valve (65) Test supply vacuum at "VAC" connection, replace vacuum amplifier if necessary. Test vacuum line according to function diagram. Test supply vacuum at vacuum pump (RI Engine 601, 602.91, 603.91, Combustion I, 07.1-160). Specification: > 700 mbar.
Vacuum control valve (65)	<p>a) automatic transmission Connect vacuum tester to "VCV" connection of vacuum amplifier (123) with Y distributor</p> <p>b) manual transmission Connect vacuum tester to connection 2 of switchover valve (Y27) with Y distributor (head connection vertical).</p>	Engine idling Engine off Accelerator control to full load position. Engine idling Engine off Accelerator control to full load position	> 350 mbar > 300 mbar (USA) < 10 mbar > 350 mbar < 10 mbar	Test vacuum lines according to function diagram. Test supply vacuum Specification > 700 mbar Adjust vacuum control valve (65)







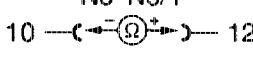

¹⁾ Only with automatic transmission

Test program components test

Test step/ Test scope	Tester/ Test connection	Operation/ Requirement	Specification	Possible cause/ Remedy
Switchover valves (Y27, Y28) Test voltage supply	<p>Y27</p> <p>1 —(←(V)→)— 2</p>	<p>Engine at 1100 ± 50 rpm</p> <p>3200 ± 50 rpm as of approx. 10/93: 2850 ± 50 rpm</p>	<p>11–14 V</p> <p>< 1 V</p>	<p>ARF/variable intake manifold system control unit (N37/3)</p> <p>ELR/ARA control unit (N8/1) or ELR control unit (N8)</p>
	<p>Y28</p> <p>1 —(←(V)→)— 2</p>	<p>Engine at 1250 ± 50 rpm</p> <p>2500 ± 50 rpm</p>	<p>11–14 V</p> <p>< 1 V</p>	<p>Oversvoltage protection relay, 9-pin (K1/2)</p> <p>Starter ring gear speed sensor (L3)</p> <p>Plug connection, starter ring gear speed sensor (L3x1)</p> <p>Altitude sensor B18 only </p> <p>Wiring</p>
Switchover valve (Y27) Test vacuum supply	Connect vacuum tester to connection 3 of switchover valve (Y27) with Y distributor.	<p>Engine at 1100 ± 50 rpm</p> <p>3200 ± 50 rpm as of approx. 10/93: 2850 ± 50 rpm</p>	<p>370 ± 15 mbar</p> <p>325 ± 15 mbar </p> <p>< 10 mbar</p>	<p>Vacuum control valve (65)</p> <p>Vacuum amplifier (123) 1)</p> <p>Test supply vacuum</p>
Switchover valve (Y28) Test vacuum supply	Connect vacuum tester to connection 3 of switchover valve (Y28) with Y distributor.	<p>Engine at 1250 ± 50 rpm</p> <p>2500 ± 50 rpm</p>	<p>> 700 mbar</p> <p>< 10 mbar</p>	<p>Test supply vacuum</p>
Starter ring gear speed sensor (L3) Voltage	<p>N37/2</p> <p>11 —(←(V)→)— 2</p>	<p>Unplug control unit (N37/3) with engine switched off</p> <p>Engine idling</p>	<p>> 3V ~ 2)</p>	<p>ELR/ARA control unit (N8/1) or ELR control unit (N8)</p> <p>Oversvoltage protection relay, 9-pin (K1/2)</p> <p>Plug connections, engine wiring harness, 12-pin (X26/7)</p> <p>(L3), clearance, dirt</p> <p>Plug connection, starter ring gear speed sensor (L3x1)</p> <p>Wiring</p>

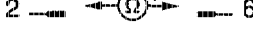
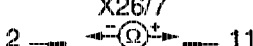
1) Only with automatic transmission
2) Voltage rises as engine speed increases

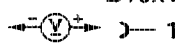
Test program components test

Test step/ Test scope	Tester/ Test connection	Operation/ Requirement	Specification	Possible cause/ Remedy
Resistance	N8-N8/1 10  12	Engine off Control unit (N8-N8/1) removed	Beru: 527 Ω ¹⁾ ± 10 % VDO: 1900 Ω ¹⁾ ± 10 % AB-Elektronik 1040 Ω ¹⁾ ± 10 %	(L3), clearance, dirt Plug connection, starter ring gear speed sensor (L3x1) Wiring
Wiring	N8-N8/1 L3x1 10  2 12  1 N37/3 N8-N8/1 2  6	Engine off Control unit (N8-N8/1) removed Plug connection (L3x1) separated Control units (N8-N8/1) and (N37/3) removed	< 1 Ω < 1 Ω	
Microswitch (S27/6)	X26/7 2  5 2  6	Engine off Plug connection (X26/7) separated	Idling < 1 Ω Full load ∞ Ω	(S27/6) Wiring
AC compressor cutoff	X26/7 2  11	Engine off Plug connection (X26/7) separated	Idling ∞ Ω Full load < 1 Ω	(S27/6) Wiring
Altitude sensor B18 only  Voltage	B18 B18x1   1	Connector (B18x1) half unplugged Engine at 1250 ± 50 rpm	11-14V ²⁾	B18
Resistance	B18 2  1	Connector (B18x1) unplugged	< 1 Ω ²⁾	B18

¹⁾ Measured at ambient temperature of 20 °C (each 10 °C change in ambient temperature alters resistance by 4 %)

²⁾ Measured up to 780 ± 25mbar air pressure.

Note

Control module of EGR/variable intake system
(N37/3) modified as of approx. 10/93. Cut-off
speed of EGR function modified to avoid blue
exhaust. Control module part no.:
061 545 95 32 or 016 545 91 32.