

07.1-8317 Adjusting microswitch at injection pump

Operation no. of operation texts and work units or standard texts
and flat rates:
07-8317

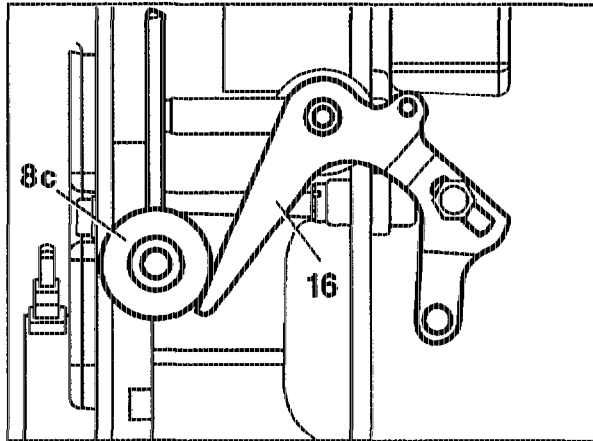

P07-6212-13

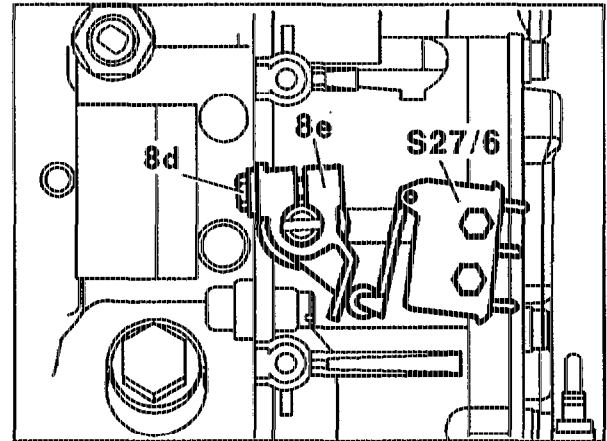

P07-6211-13

Engine 605.911

Intake manifold	remove, install (14-1310).
Bracket at rear of injection pump	remove, install.

Engine 606.910

Resonance intake manifold	remove, install (14-1961).
---------------------------------	----------------------------

All models

Vacuum control valve	remove, install.
Locking bolt (8d) of adjusting cam	slacken.
Gauge (8c)	fit on to full load stop.
Adjusting lever (16) of injection pump	turn until it is resting against the gauge (8c).

Adjusting without multimeter

Adjusting cam (8e)	turn counter-clockwise until both microswitches are heard to operate (clicking noise).
--------------------------	--

Adjusting with multimeter

Adjusting cam (8e)

turn counter-clockwise until the readout in multimeter is $\infty \Omega$ (see connection illustration).

Locking bolt (8d) of adjusting cam

Note

Microswitch (S27/6) operates at 15° and 10° before full load.

tighten and remove gauge.

Shop-made tool

Gauge

250 mm long, 3 mm dia. wire.

Washer outer dia. 30 mm, inner dia. 10 mm.

The wire must be welded to the washer.

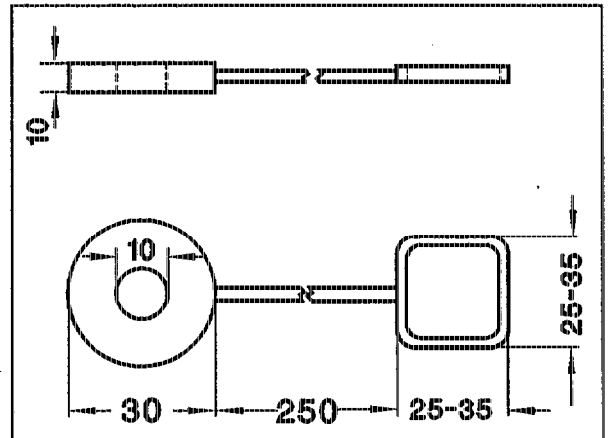

P07-6080-13

Connection diagram of microswitch

Unplug coupling at microswitch (S27/6) and connect multimeter to connector 1 and 3.

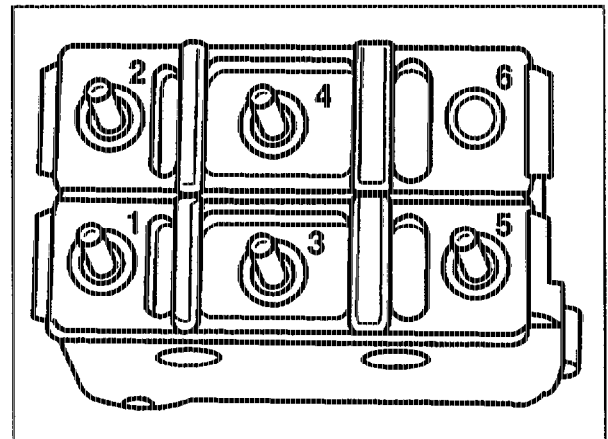

P07-6512-13