

C2









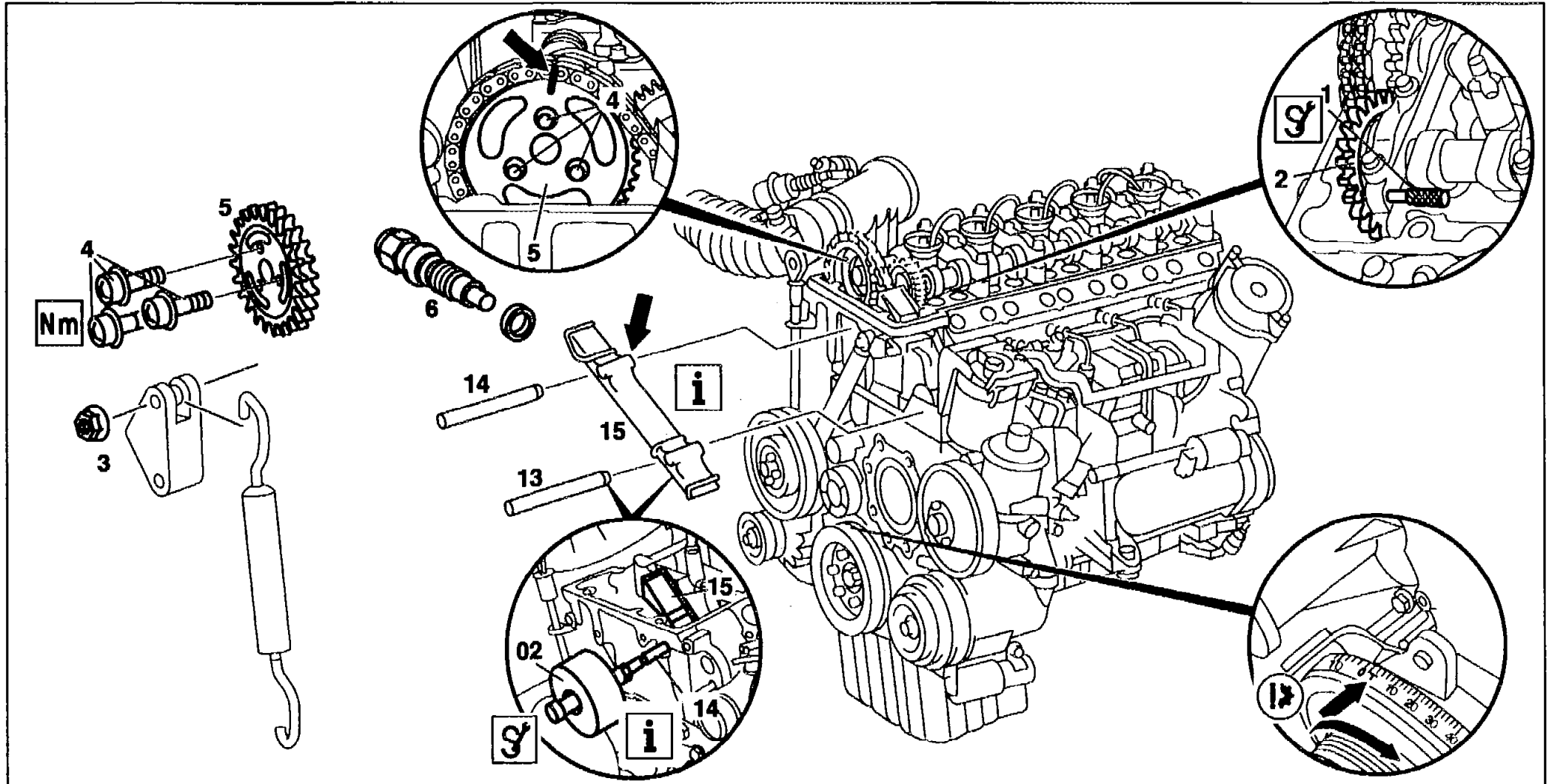

AR05.10-P-8432HB

Removing and installing slide rail in cylinder head

14.1.98

ENGINE 604, 605, 606



 	Removing, installing		
1	Remove poly V-belt		AR13.22-P-1202HA B7
		Engine 606 in model 463	AR13.22-P-1202GG
2	Remove cylinder head cover		AR01.20-P-5014HA
3	Position piston of cylinder 1 to ignition TDC	 Rotate engine at crankshaft in direction of rotation of engine	
4	Fix inlet camshaft in position with retaining pin (1)	 Retaining pins	111 589 03 15 00
5	Mark camshaft sprocket (5) to timing chain (arrow)	 Installation: pay attention to colored marking. Inspect basic position of camshaft.	AR05.20-P-6020HA C3
6	Remove chain tensioner (6)		AR05.10-P-7800HA M1
7	Remove camshaft sprocket (5)		BA05.20-P-1001-01A
8	Pull out slide rail pins (13, 14) in cylinder head	 Impact extractor  Threaded bolt  Extractor  Installation: coat bearing pins with sealant.	AR01.30-P-5800-04A P15 116 589 20 33 00 116 589 01 34 00 605 589 00 33 00 BR00.45-Z-1010-01A

9	Remove slide rail (15)	<p>i Installation: install slide rail so that the two mounting holes for the slide rail pins are facing up (arrow) and the open side of the slide rail is pointing in opposite direction of travel.</p> <p>Timing chain drive as-built description</p>	<p>GF05.10-P-4000HA</p> <p>F1</p>
10	Install in the reverse order		

Nm Camshaft

Number	Designation	Engine 604, 605, 606
BA05.20-P-1001-01A	Bolt of camshaft sprocket	Nm 18

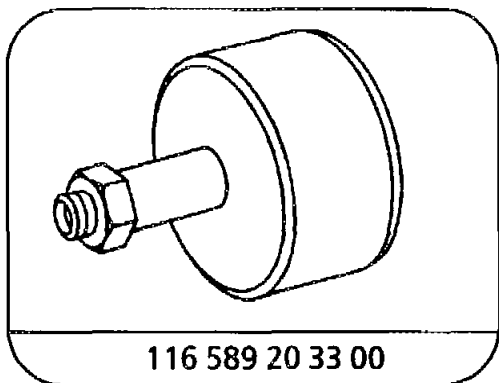

Impact extractor

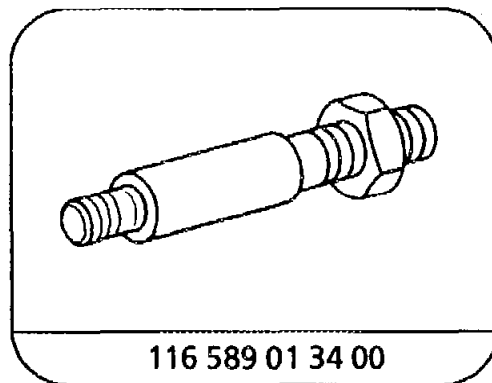

Threaded bolt

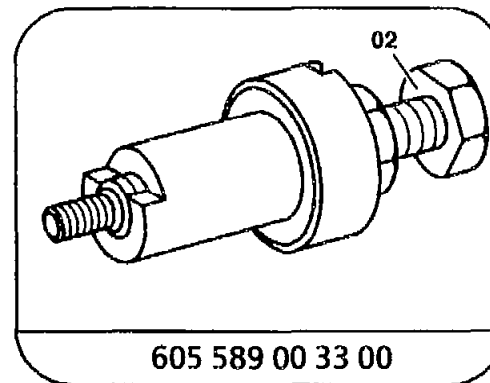

Extractor

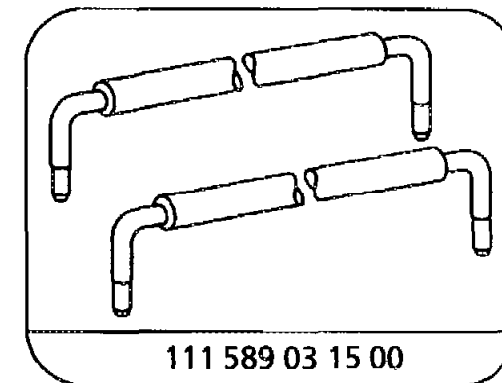

Retaining pins

Repair products

Number	Designation	Order number
BR00.45-Z-1010-01A	Loctite 574 sealant	001 989 89 20