

J2

AR05.20-P-6010HA

Checking basic position of camshafts

2.4.93

ENGINE 604, 605, 606 /

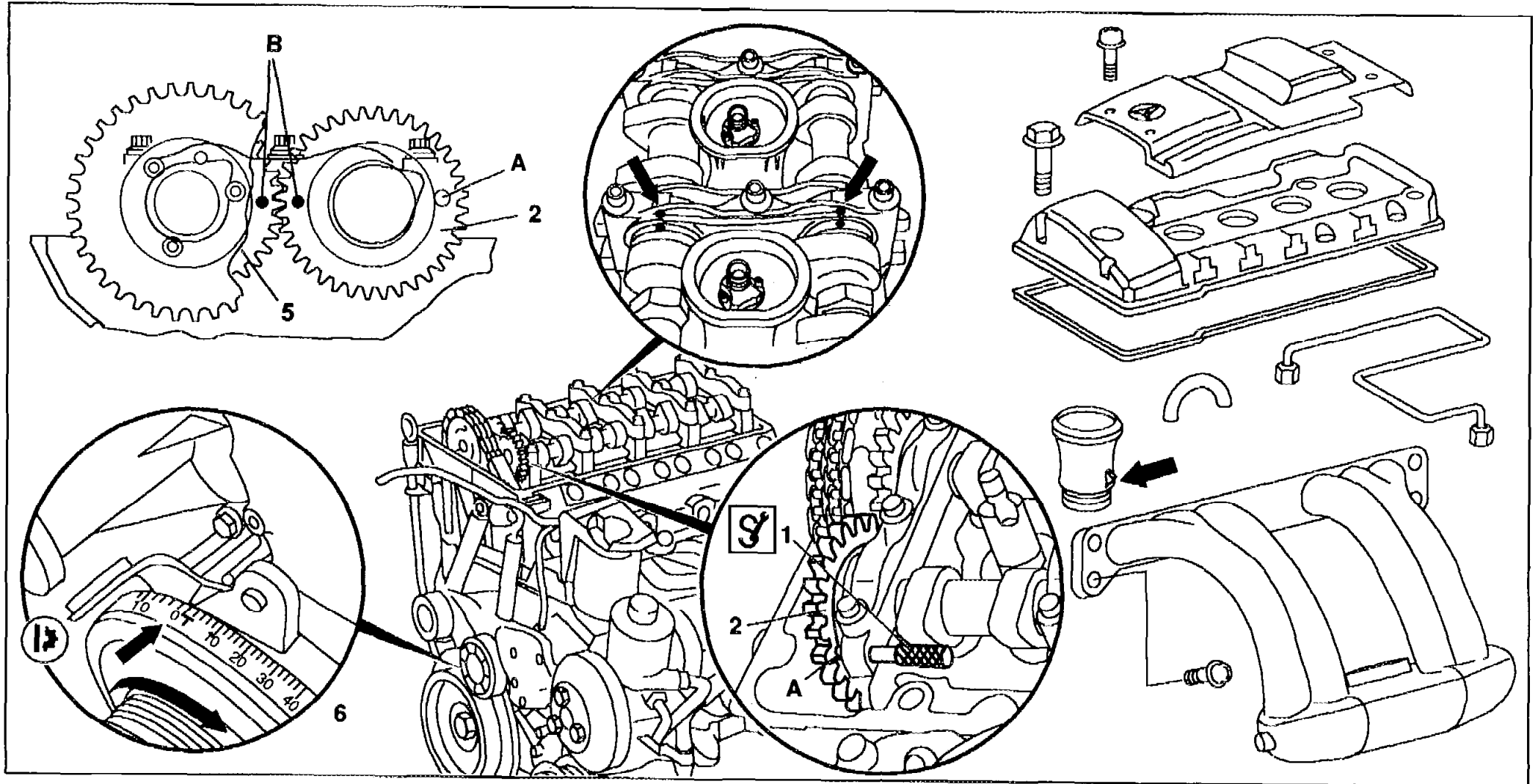
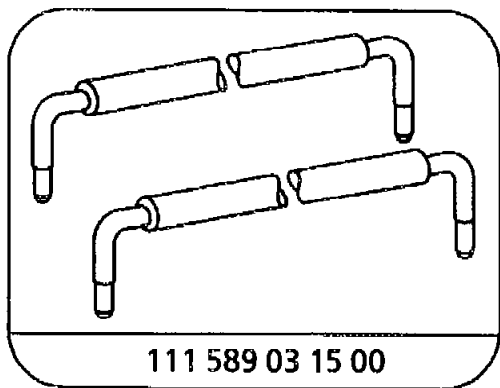



Fig. item, etc.	Procedure		
④ 6	Position piston of cylinder 1 to ignition TDC	Crank engine at crankshaft. <b>Do not</b> crank engine backward or crank engine at the camshaft.	
1, 2	Lock inlet camshaft	ⓘ Insert the retaining pin (1) through camshaft bearing cap 1 into the hole (A) in the inlet camshaft gear (2).	
		☞	111 589 03 15 00
2, 5	Check basic position of camshafts	ⓘ The two $\varnothing$ 1.5 mm holes (B) in the camshaft gears (2, 5) must be opposite each other. If necessary after checking ↓ Set basic position of camshafts ⓘ The injection pump should be positioned before start of delivery at cylinder 1	AR05.20-P-6020HA <b>C3</b>



Fixing pin