

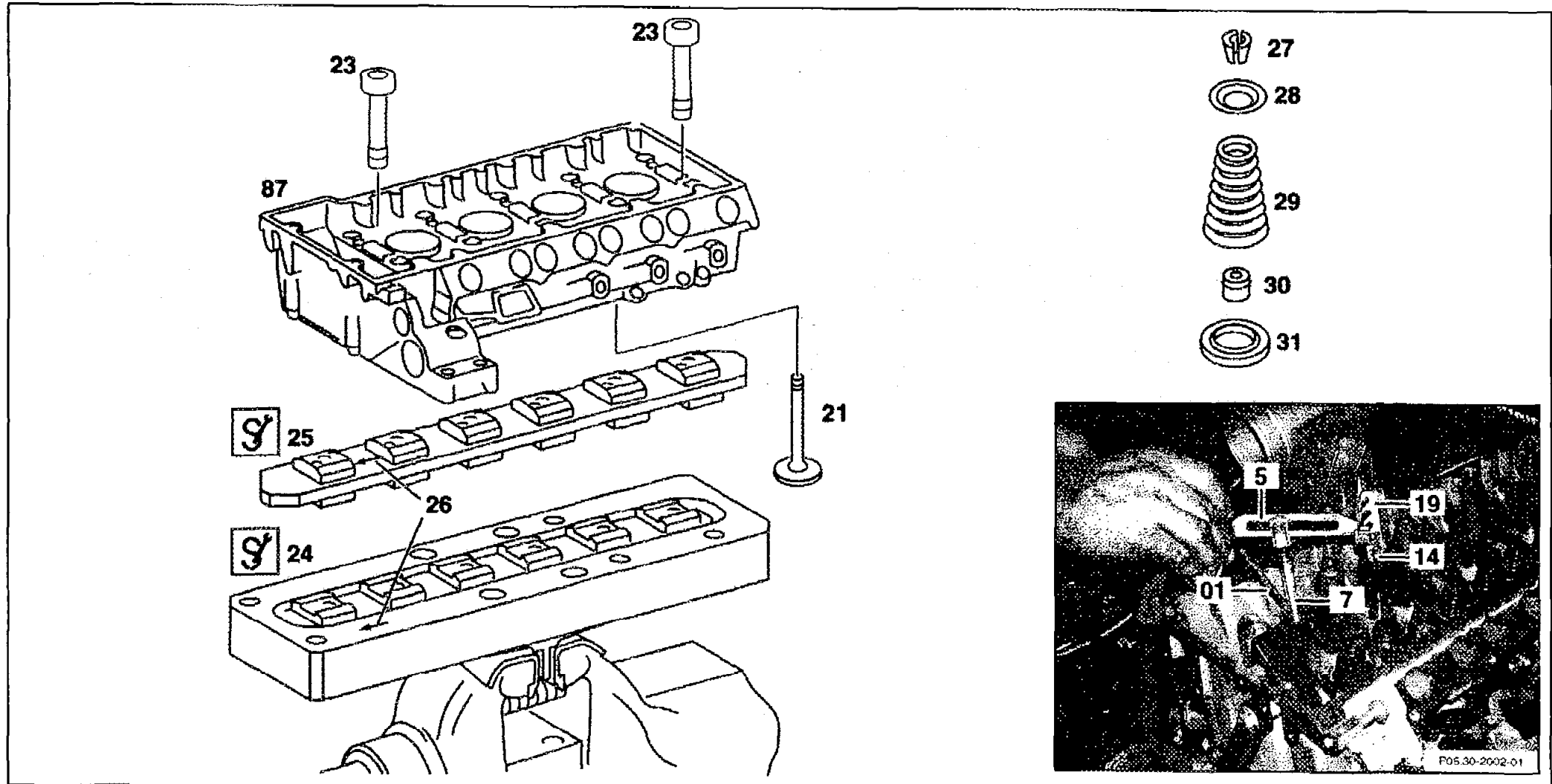













D5	AR05.30-P-3511B	Removing, installing valves
----	-----------------	-----------------------------

ENGINE 604, 605, 606 /



 	Removing, installing		
1	Remove cylinder head (87)	Model 124, 140, 202, 210  Model 463	AR01.30-P-5800HA  AR01.30-P-5800GG
2	Mount cylinder head (87) on assembly board (24)	  Place insert (25) with direction of travel arrow (26) facing forward and with corresponding side into assembly board (24).  Attach cylinder head (87) to assembly board (24) with a cylinder head bolt (23) at the front and rear with front of cylinder head facing toward direction of travel arrow (26).  The cylinder head (27) can be fitted on with intake manifold and exhaust manifold.	111 589 02 59 00
3	Fit assembly tool for valves onto cylinder head	 Screw retaining fork (14) (M7×60) with hinged fork (19) into hole of camshaft housing attachment at cylinder head.	



4	Remove valve springs (29)	<p>Attach detent depressor (5) with lever handle and thrust piece (7) into hinged bearing (19). Align thrust piece (7) vertically to valve spring (22). Compress valve spring (29) and remove valve collets (20) with magnetic pin, magnetic finger or tweezers.</p> <p> Magnetic pin (02)  Magnetic finger  Tweezers</p>	<p>210 589 00 40 00 116 589 06 63 00 WH58.30-Z-1002-02A</p>
5	Use pliers to remove valve stem seals (30)	<p> Inspect valve stems for burrs, deburr if necessary. Inspect bottom valve spring retainer (31) for pitting, replace if necessary.</p> <p> Pliers</p> <p> <b>Installation:</b> oil valve stem seals. Press on valve stem seals with assembly drift by hand</p> <p> Assembly drift</p>	<p>606 589 00 37 00 604 589 00 43 00</p>
6	Take cylinder head (87) off assembly board (24) and remove valves (21)		
7	Install in the reverse order		

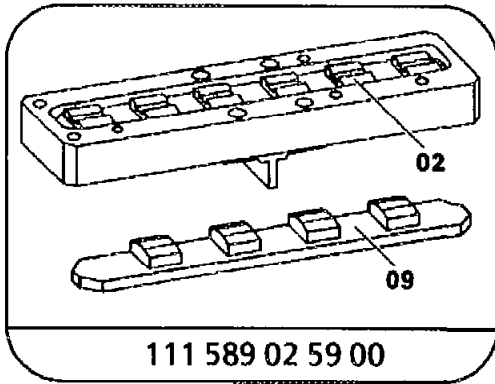

111 589 02 59 00

Assembly board

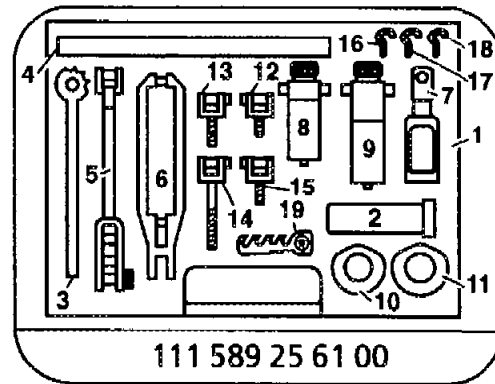

111 589 25 61 00

Valve assembly tool case

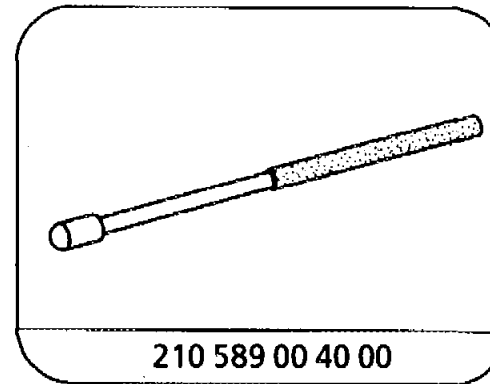

210 589 00 40 00

Magnetic pin

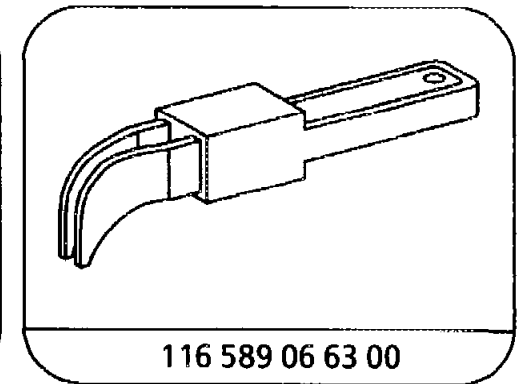

116 589 06 63 00

Magnetic finger

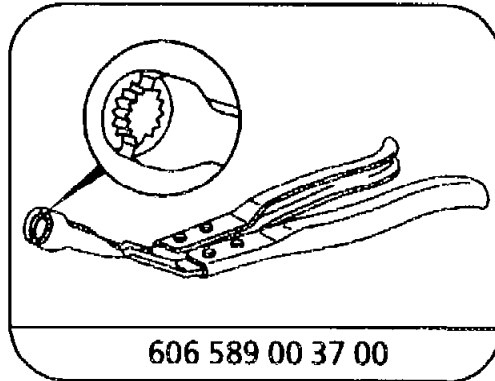

606 589 00 37 00

Pliers

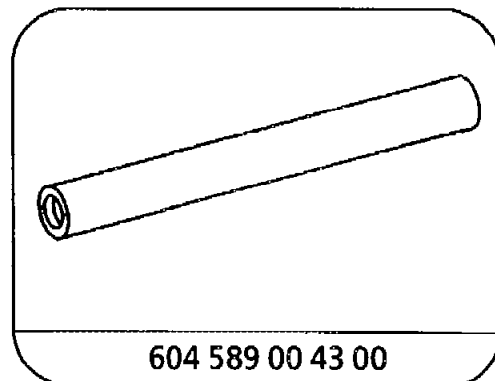

604 589 00 43 00

Drift

**Commercially available tool**

Number	Designation	Make (e.g.)	Order number
WH58.30-Z-1002-02A	Tweezers, straight 160 mm with rounded tips	Stahlwille Eduard Wille GmbH & Co Lindenallee 27 D-42331 Wuppertal 12	77500001