

**M1**

AR01.00-P-1300HA

Testing cylinder leaktightness**2.4.93****ENGINE 111, 604, 605, 606 /***Shown on engine 111*

- 1 Expansion tank
- 2 Cap
- 3 Oil filler cap
- 5 Connection hose
- 19 Spark plug
- 04 Cylinder leaktightness tester

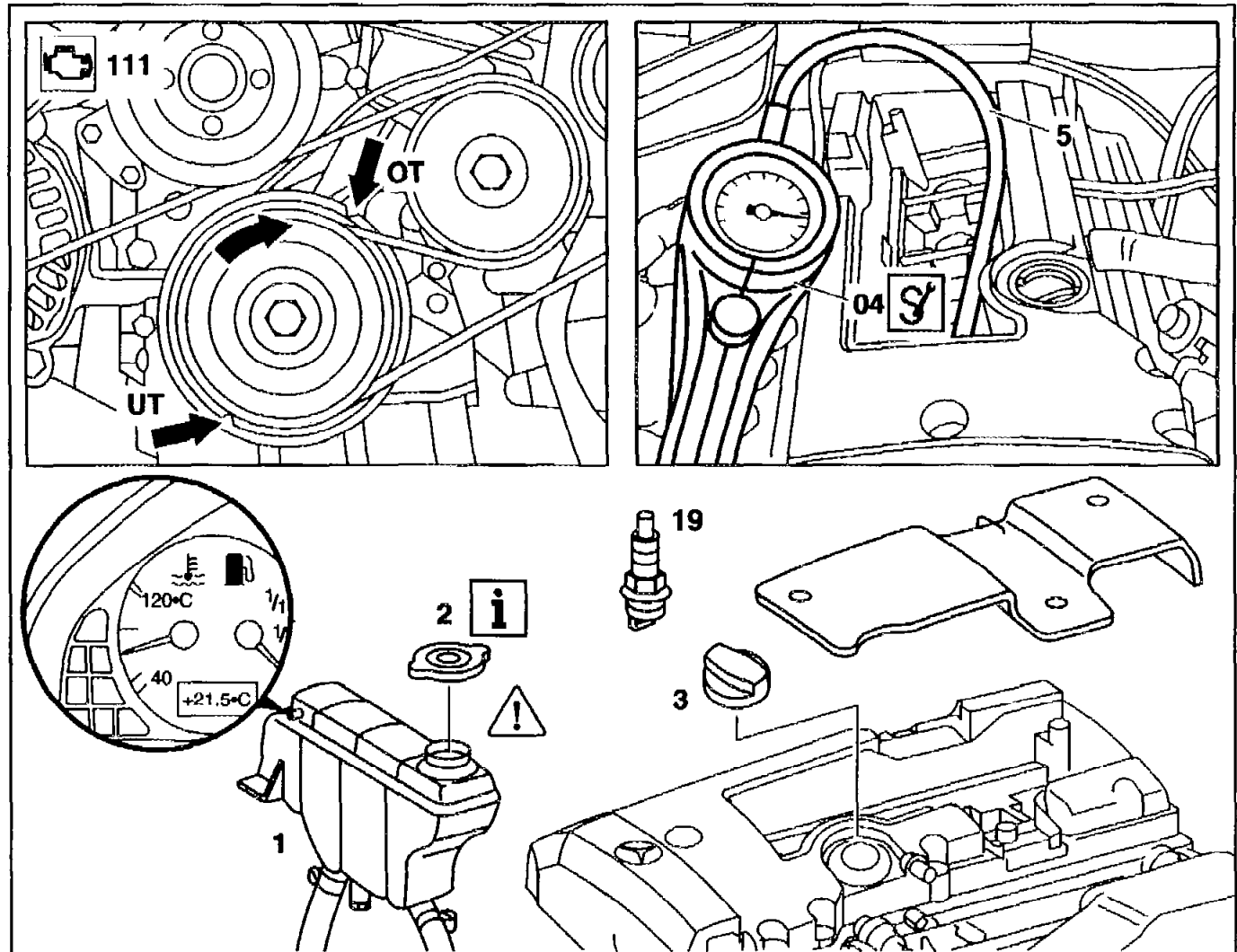

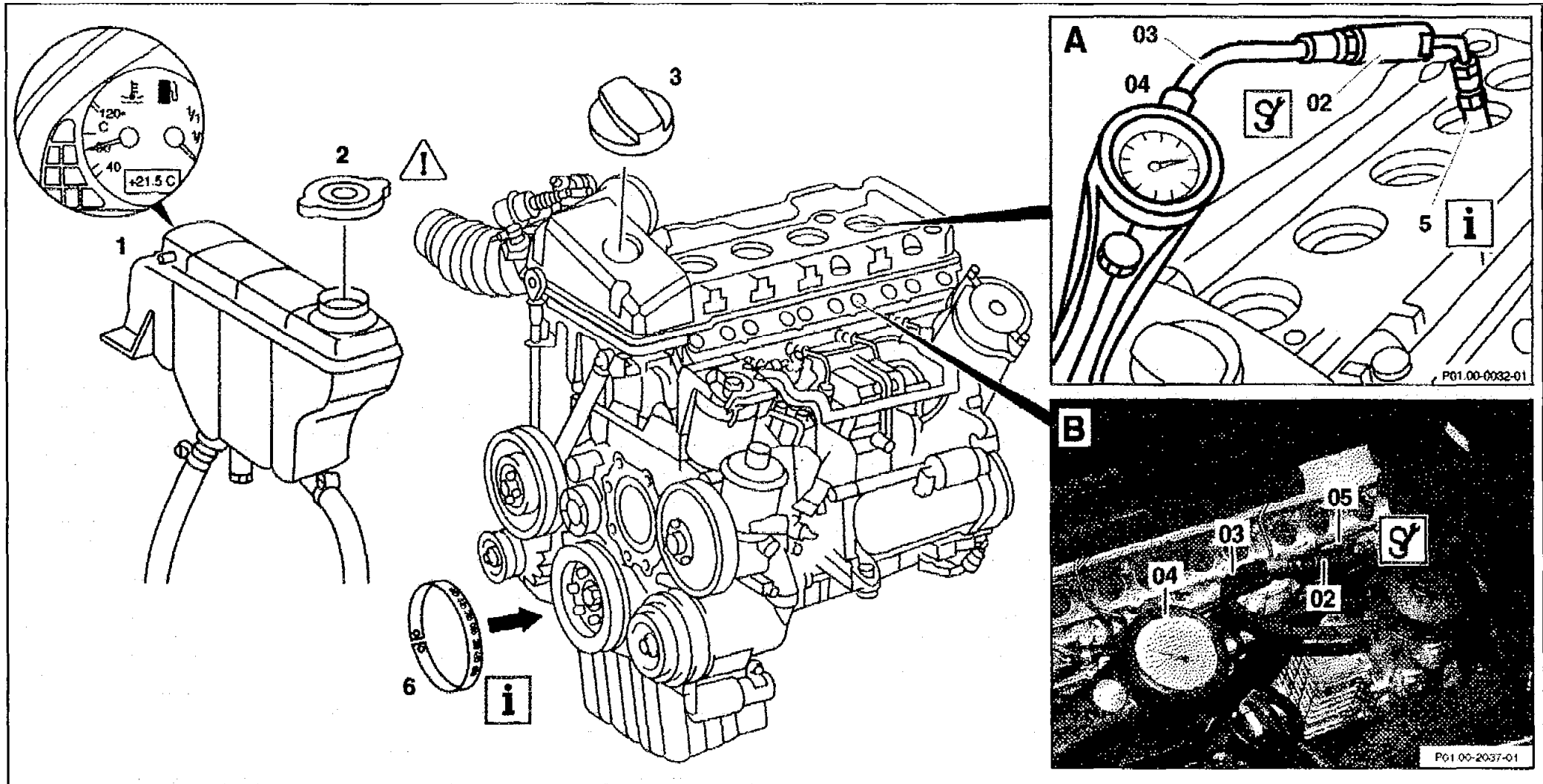





P01.00-2038-09





Shown on engine 604-606

- A Testing pressure loss through injection nozzle hole
- B Testing pressure loss through glow plug hole





- 1 Expansion reservoir
- 2 Expansion reservoir cap
- 3 Oil filler cap
- 5 Connector
- 6 Graduated scale (shop-made tool)

- 02 Knee piece
- 03 Connection hose
- 04 Cylinder leaktightness tester
- 05 Connector

	On engines 604-606 the pressure loss can be tested at the hole of the injection nozzle or of the glow plug.		
	Removing, installing		
1	Warm engine up to operating temperature (approx. 80 °C)		
 Danger!	<p>Risk of injury to skin and eyes from scalding from hot coolant which splashes out. Risk of poisoning from swallowing coolant.</p> <p>Open cap of expansion reservoir or radiator (2)</p>	<p>Do not open the cooling system unless the coolant temperature is below 90 °C. Open cap slowly and allow the pressure to release. Do not pour coolant into containers for drinks.</p> <p>Wear protective gloves, protective clothes, and eye protection.</p> <p> Cap with detent: Turn cap anti-clockwise as far as detent 1, release pressure, and then turn cap onto detent 2.</p> <p>2-position cap: Turn 2-position cap half a turn anti-clockwise, release pressure, then unscrew cap.</p>	AS20.00-Z-0001-01A H17
3.1	Remove spark plugs (19)	Engine 111	AP15.10-P-1580CA
4.1	Remove injection nozzles	Engines 604, 605, 606, for test at injection nozzle hole	AR07.03-P-6830H

5.1	Remove glow plugs	Engines 604, 605, 606, for test at glow plug hole	AR15.20-P-4111C
6.1	Attach graduated scale (6) to vibration damper	Engine 604, 605, 606  Attach graduated scale to pin of vibration damper	
 WF	Graduated scale for vibration damper		WF58.50-P-0330-03A D18
7	Position piston of cylinder to be inspected to ignition TDC	Rotate engine at crankshaft Piston at TDC if marking number on vibration damper as follows: Engine 604 TDC cylinder 1 and 4, 180° cylinder 2 and 3 Engine 605 TDC cylinder 1, 72° cylinder 2, 144° cylinder 4, 216° cylinder 5, 288° cylinder 3 Engine 606 TDC cylinder 1 and 6 120° cylinder and 4 240° cylinder 3 and 5	
8	Connect cylinder leaktightness tester (04)	 Engine 111 Calibrate tester and screw connection hose into spark plug hole. Connect cylinder leaktightness tester (04), engines 604, 605, 606 	WH58.30-Z-1030-05A AR01.00-P-1300-01HA E14 604 589 00 63 00



		 	602 589 00 25 00 WH58.30-Z-1030-05A
	Testing		
9	Pressurize cylinder with compressed air and read off pressure loss at tester (04); if pressure loss is high, determine cause	 If crankshaft rotates: ↓ Install retaining lock for crankshaft. Engine 604, 605, 606	BE01.00-P-1001-02Z BE01.00-P-1002-02Z BE01.00-P-1003-02Z AR03.30-P-5000HA
10	Carry out the test of the remaining cylinders in the firing order of the engine	Firing order	AR01.00-P-1300-03HA G14
11	Install in the reverse order		

**Cylinder leaktightness**

Number	Designation	All engines
BE01.00-P-1001-02Z	Cylinder leaktightness, permissible losses total readout	% ≤ 25
BE01.00-P-1002-02Z	Cylinder leaktightness, permissible losses at valves and cylinder head gasket	% ≤ 10
BE01.00-P-1003-02Z	Cylinder leaktightness, permissible losses at pistons and piston rings	% ≤ 20

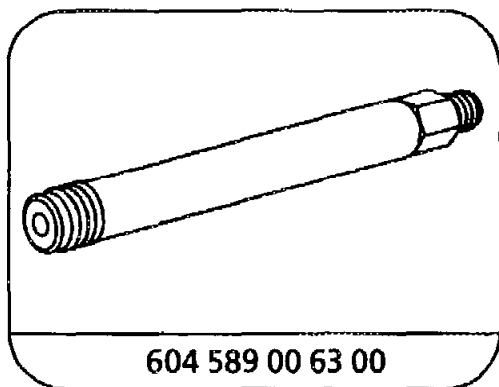

Connector

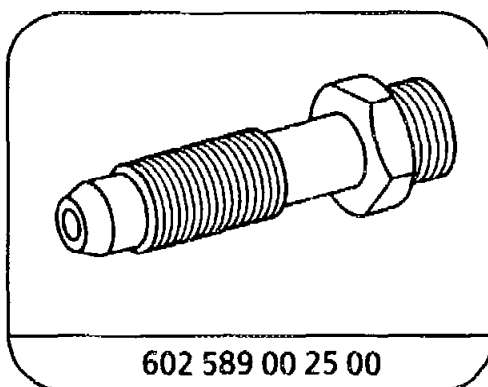

Adapter

**Commercially available tools (see Workshop Equipment Manual)**

Number	Designation	Make (e.g.)	Order number
WH58.30-Z-1030-05A	Cylinder leaktightness tester	Bosch	0 681 001 901 EFAW 210 A
WH58.30-Z-1002-05A	M22 × 1.5 mm/ R1/4" connection for injection nozzle	Bosch	604 589 06 63 00