

06

AR30.20-P-1262E

Removing and installing electronic accelerator actuator with throttle valve body

15.8.94



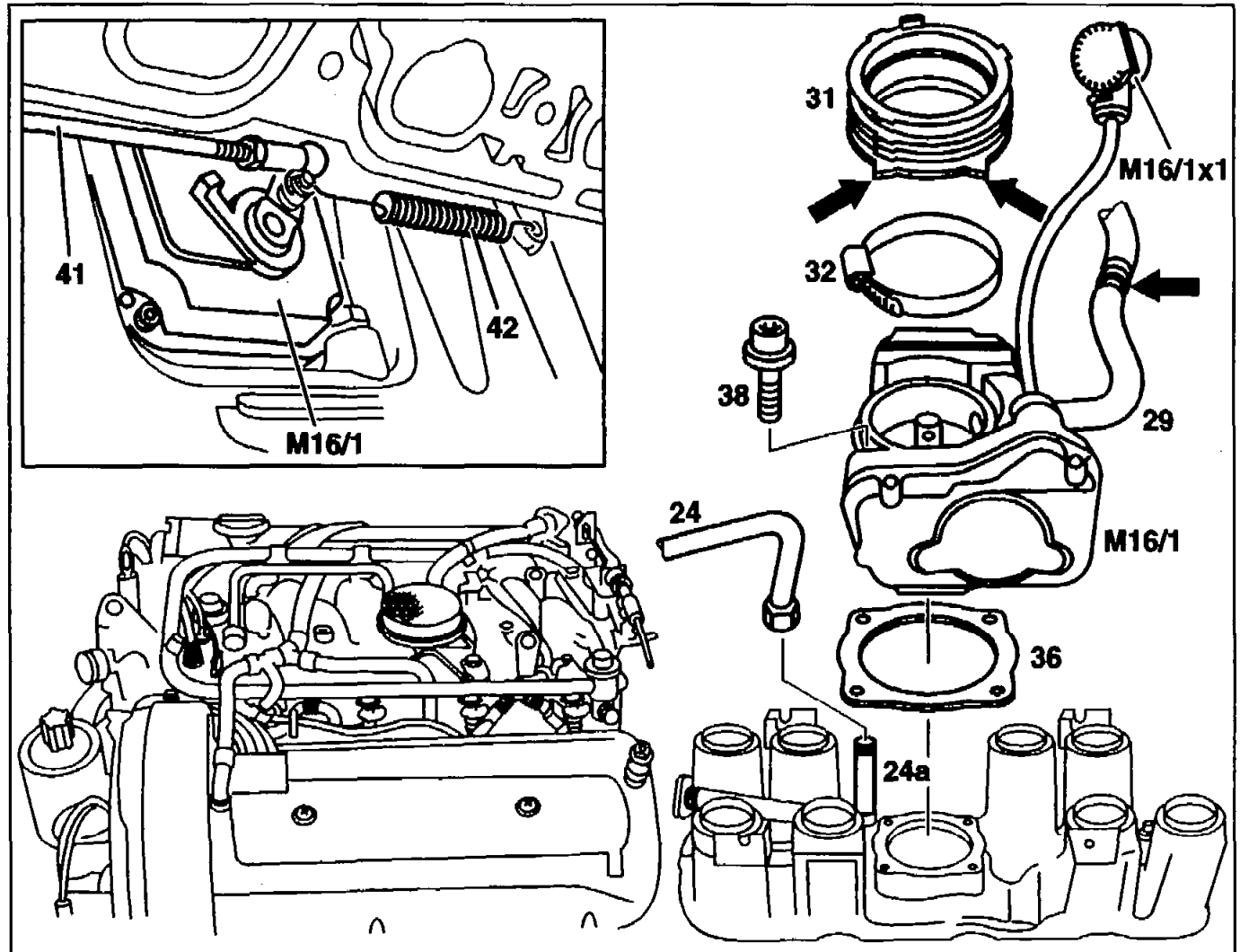



ENGINE 119.97





- 24 Vacuum pipe
- 24a Vacuum pipe
- 29 Vent hose
- 31 Connection hose
- 32 Hose clip

- 36 Gasket
- 38 Bolts
- 41 Connecting rod
- 42 Return spring

- M16/1 Electronic accelerator actuator
- M16/1x1 Electronic accelerator actuator connector

	Removal, installation		
1	Remove hot wire mass air flow sensor, install		AR07.41-P-1453E B1
2	Slacken hose clip (32) and take off connecting hose (31)	 Pay attention to installation position (arrows)	WH58.30-P-1002-06A
3  BT	Unplug actuator connector (M16/1x1) and detach cable Routing of electronic accelerator cable Routing of electronic accelerator cable Routing of electronic accelerator cable modified	 When replacing actuator, ensure the electric cables are correctly routed Model 124.036 up to 06/93 Model 124.034 Model 124.036 as of 07/93	AR30.20-P-1262-01A B16 AR30.20-P-1262-01B D16 BT30.20-P-0001-01A G17
4	Detach connecting rod (41) and return spring (42)	 Pay attention to installation position of return spring (42)	
5	Disconnect vacuum pipe (24, 24a) for brake servo unit		000 589 70 03 00
6	Detach vent hose (29) for crankcase ventilation at separation point (arrow)		

7	Unscrew bolts (38)	 Replace microencapsulated bolts 	BA30.20-P-1001-01A
8	Tilt electronic accelerator actuator (M16/1) together with throttle valve body up at the accelerator control end, turn anti-clockwise 1/4 turn and take off	 Clean sealing surface, replace gasket (36). Fit gasket onto actuator with Hylomar	BR00.45-P-1011-01A
9	Install in the reverse order		
10	Adjust accelerator control	with ASR code 471a without ASR code 471a	AR30.10-P-1010EA M5 AR30.10-P-1010EB A6

 Electronic accelerator actuator

Number	Designation	Engine 119
BA30.20-P-1001-01A	Electronic accelerator to intake manifold 	25

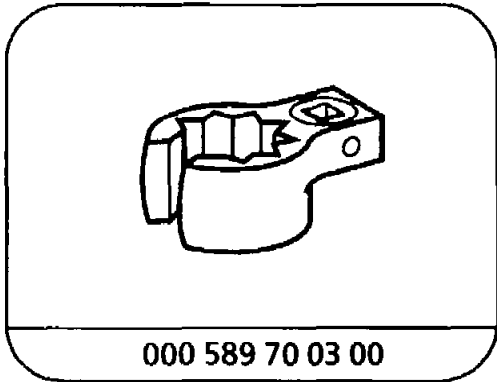

000 589 70 03 00

Box wrench socket

Commercially available tools (see Workshop Equipment Manual)

Number	Designation	Make (e.g.)	Order number
WH58.30-P-1002-06A	7 mm wrench hexagon on flexible shaft for hose clips with worm drive	Hazet Güldenwerther Bahnhofstraße 25-28 D-42857 Remscheid	426-7

Repair product

Number	Designation	Order number
BR00.45-P-1011-01A	Hylomar sealant	001 989 25 20