



M4

AR15.12-P-1928E

Removing and installing high voltage distributor cap, high voltage distributor rotor

10.8.94

ENGINE 119.97

- 13 High voltage distributor rotor
- 14 Follower
- 14a Follower slot
- 15 High voltage distributor cap
- 16 Screening cap
- 17 Cover
- 18 Hood
- Arrow Locating pin

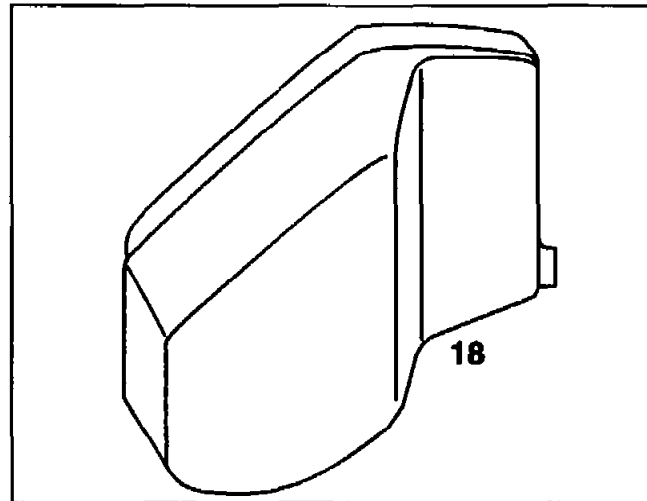

P15.12-0235-01

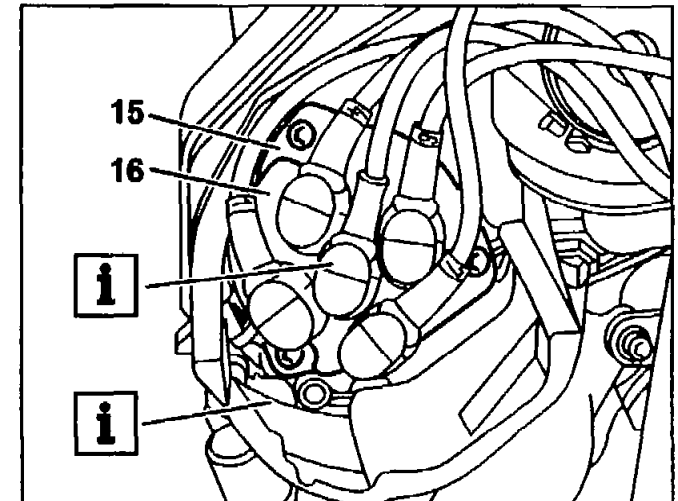



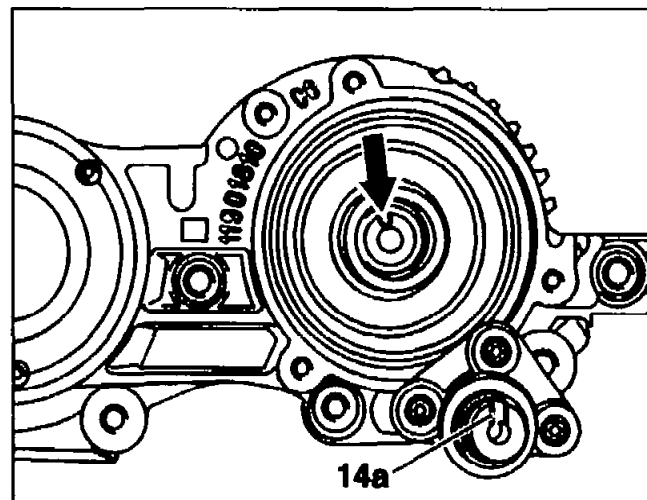

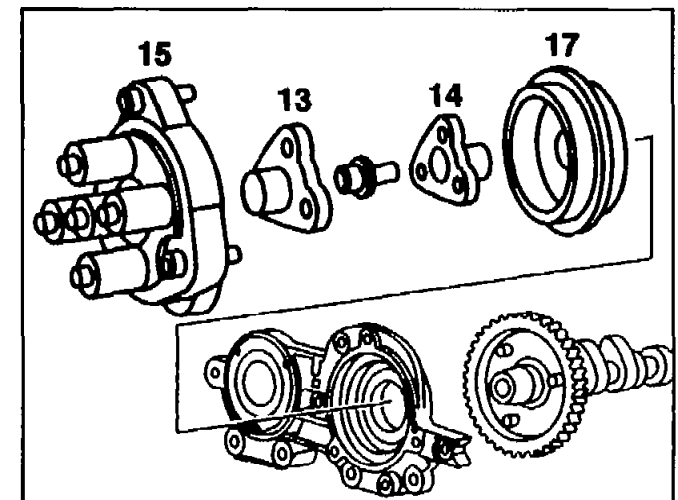

P15.12-0236-01



P15.12-0237-01



P15.12-0238-01

Fig. item, etc.	Work instructions		
 Danger!	Hazard from contact with parts conducting high voltages	Do not touch parts conducting high voltages. Persons who wear electronic implants (e.g. heart pacemakers) must not carry out any work on the ignition system.	AS15.10-Z-0001-01A
	Notes on avoiding damage to the ignition system	Engine 104, 111, 112, 113, 119, 120 with ME-SFI fuel injection and ignition system Engine 103, 104, 119 with CFI fuel injection system Engine 104, 119, 120 with LH-SFI fuel injection system	AH15.10-P-0002-01D A17 AH15.10-P-0002-01E B17 AH15.10-P-0002-01F C17
	Ignition cables	install in the correct order at the high voltage distributor caps right: 1-4-6-7 left: 5-8-3-2	
	O-ring	examine, replace if necessary	
13  BT	High voltage distributor rotor High voltage distributor rotor with stiffening ribs	slacken screws and take off	BT15.12-P-0002-01A C18
14	Follower	 Installation: pay attention to locating pin (arrow) and follower slot (14a)	
15	High voltage distributor cap	slacken hexagon socket screws and take off	
18	Hood of high voltage distributor		