

03-3170 Replacing piston rings

Preceding work:
Pistons removed (03-3160).

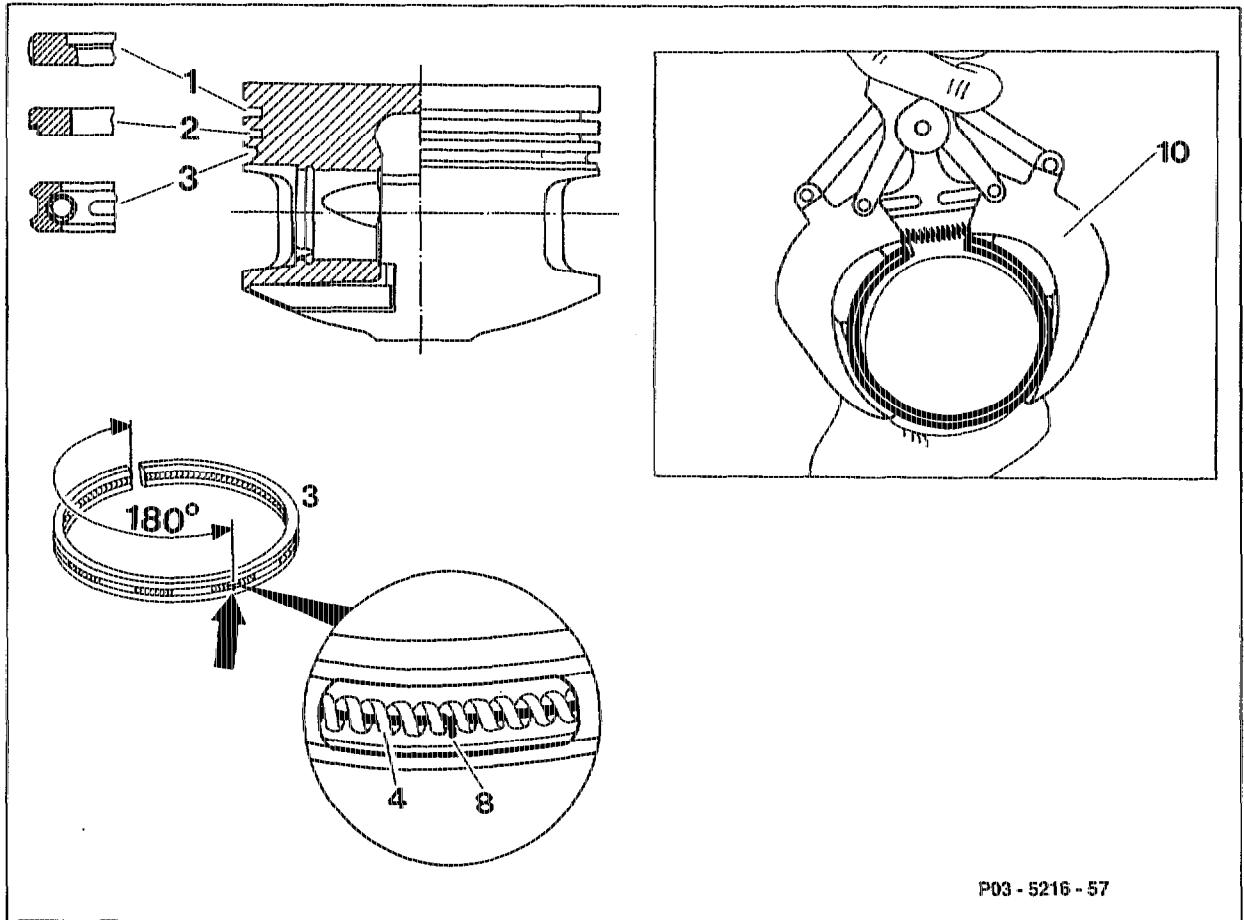

P03 - 5216 - 57

- 1 Plain compression ring
- 2 Taper-faced hook scraper ring

- 3 Double bevelled coil spring loaded oil control ring
- 4 Coil spring

End clearance of piston rings
Piston rings

measure.

remove with pliers (10), install, special tool
000 589 51 36 00.

Note

Pay attention to installation position, "Top" faces up. Hooked spring (8) in oil scraper ring (3) is installed offset 180° to joint (arrow).

Special tool

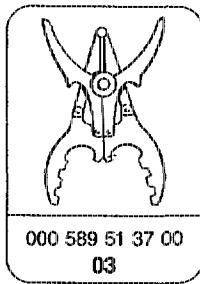

Test data in mm

End clearance of piston rings	Groove 1	0.05 – 0.08
	Groove 2	0.01 – 0.03
	Groove 3	0.01 – 0.04