

01-1240 Repairing tapped holes for transmission mounting

Preceding work:
Engine removed (01-0300)

Engine 119.960

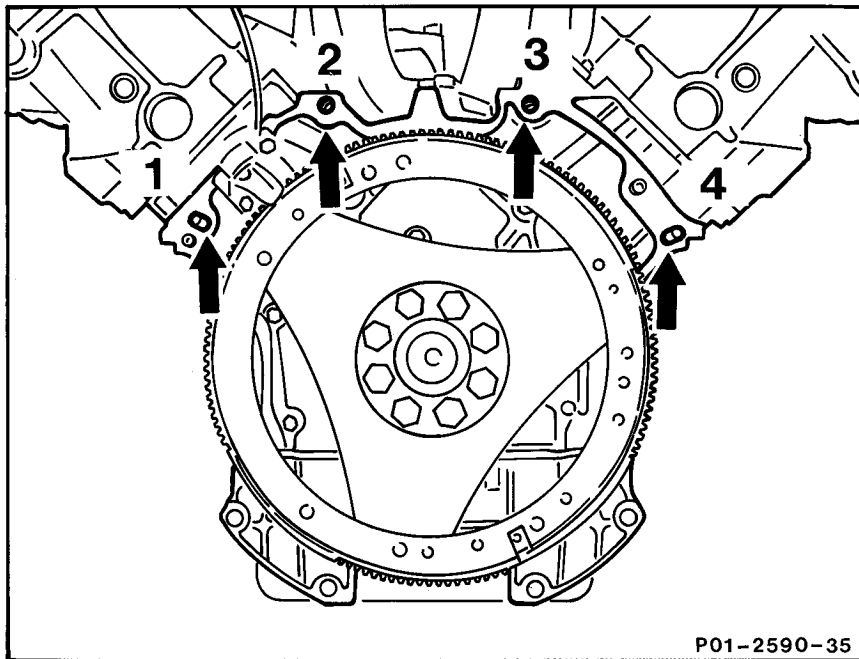

P01-2590-35

Core hole with HSS twist drill bore out (step 1).
Swarf blow out (step 2).



Bore (4) with oil return duct connect (step 2).
Right cylinder head remove, install (01-4150).
Oil sump remove, install (01-3100).
Swarf in oil duct blow out from above.
HELI-COIL mounting thread tap (step 3).
Swarf blow out (step 4).

HELI-COIL threaded insert M10 screw in (step 5).



Insertion depth observe (step 5).

Tang of HELI-COIL threaded insert	break off with a drift, remove.
Ease of movement of threads	check (step 7).
Stud bolts	screw into bore 1 and 4 (step 8).

Commercial tools

HELI-COIL tap M10
 Art. No. 0140 0100104

HELI-COIL threaded insert M10
 Standard Art. No. 0130 0100020

e. g. Böllhoff & Co.
 D-4800 Bielefeld 14

HELI-COIL hand installation tool M10
 Art. No. 0150 0410000-1

Note

Torn threads for transmission mounting should be replaced by HELI-COIL standard threaded inserts, Art. No. 0130 0100020 with a length corresponding to twice the diameter of the bolts (11 threads).

Reconditioning

1 Drill core hole approx. 27 mm deep with an 10 mm dia. HSS twist drill.

Minimum core hole diameter 10 mm,
 maximum 10.3 mm.

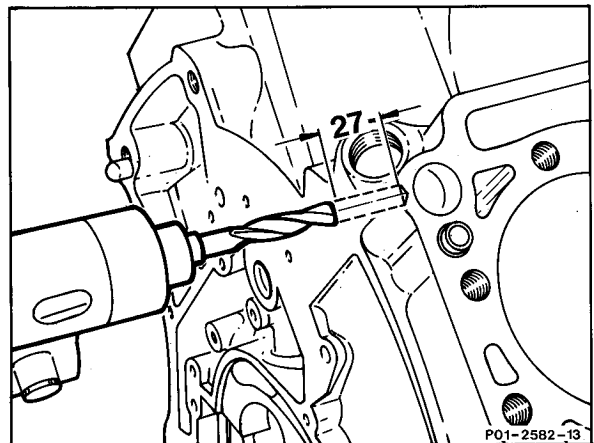

Handwritten signature

2 Blow out swarf.



Bore (4) merges into oil return duct.
When repairing bore (4), remove and install right cylinder head (01-4150).
Remove and install oil sump (01-3100).

1 and 4 M10 stud bolt
2 and 3 M10 thread

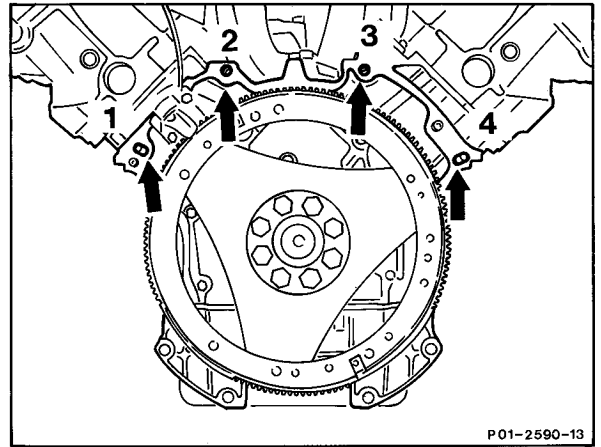

P01-2590-13



Blow swarf from bore (4) out of oil duct from above (arrow).

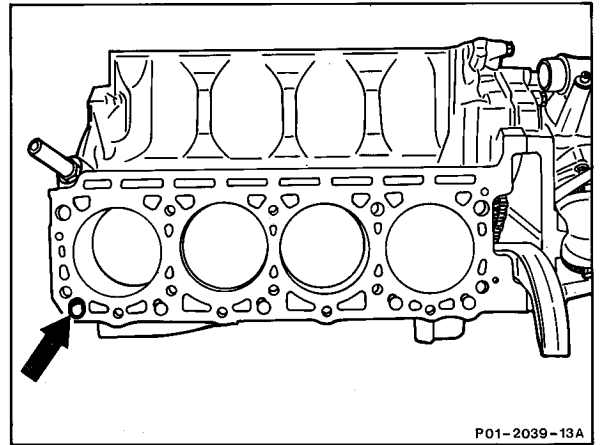

P01-2039-13A

3 Tap HELI-COIL mounting thread with HELI-COIL M10 tap (outer diameter 12.0 mm), Art. No. 0140 0100104, approx. 25 mm deep.
Lubricate tap with honing oil when performing this step.

4 Blow out swarf.



Bore (4, see step 2).

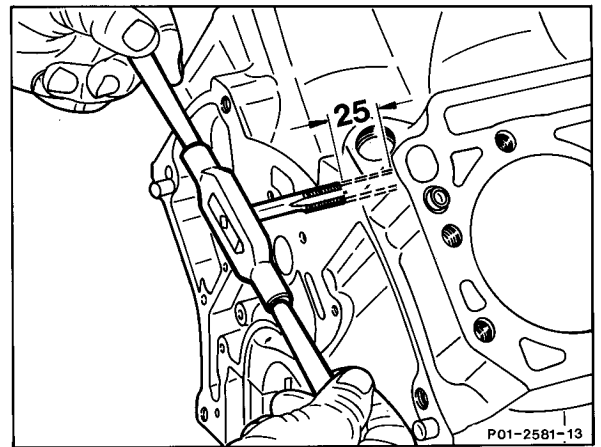

P01-2581-13

01.1311-1240/3

5 Screw in oiled HELI-COIL M10 standard threaded insert, Art. No. 0130 0100020, with the M10 hand installation tool, Art. No. 0150 0410000-1.



The top thread must stop approx. 2 mm below the mating surface.

6 Break off tang of HELI-COIL threaded insert with a drift.

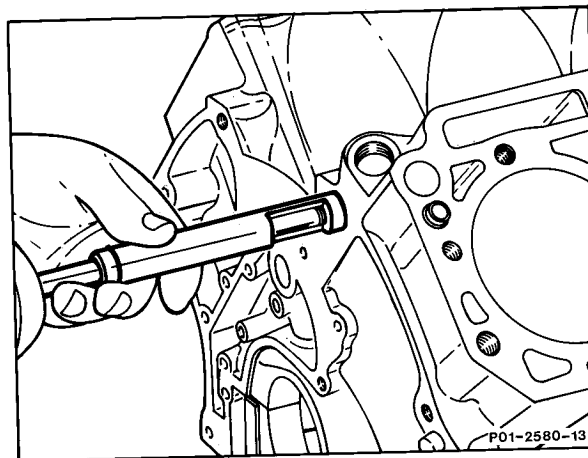

7 Examine inserted thread for possible misalignment and for ease of operation of threads by screwing in a bolt.

The insertion depth should be approx. 23 mm.

8 Install stud bolts (1) and (4).



The microencapsulated stud bolt (4) seals the oil duct in the crankcase.

The stud bolts lose their sealing effect after being removed. They may only be used once.

1 and 4 M10 stud bolt
2 and 3 M10 thread

