

## 14-3915 Removing and installing exhaust manifold

Operation No. of operation texts and work units or standard texts  
and flat rates:  
14-3915

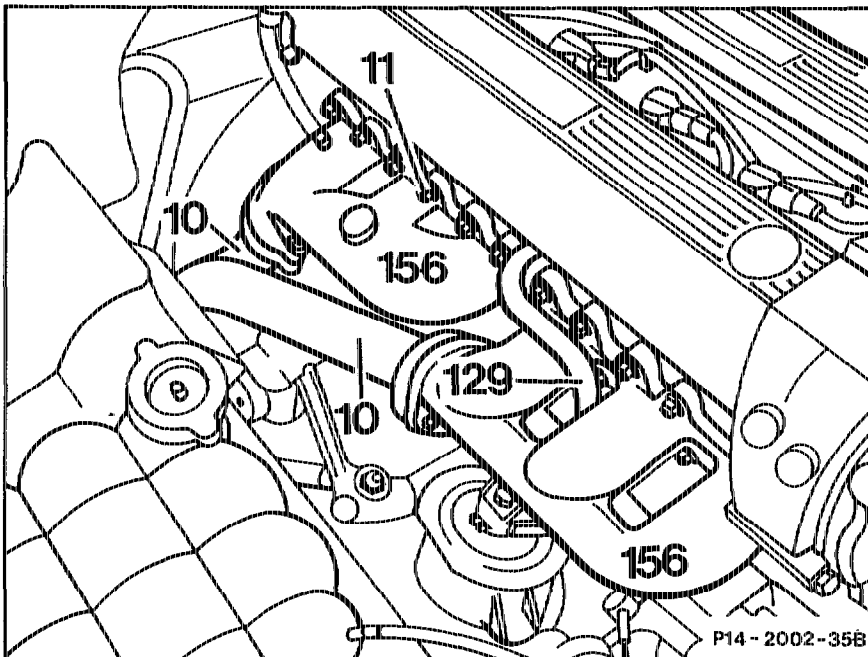

|                                |  |
|--------------------------------|--|
| Exhaust pipes (10) .....       | at exhaust manifold, unscrew, screw on.<br>Replace self-locking nuts.  |
| Exhaust support .....          | at transmission, unscrew, screw on.  |
| Air injection pipe (129) ..... | remove, install by unscrewing bolt for attaching<br>air injection pipe to cylinder head, screwing on.<br>Unscrew retaining clip from air injection pipe,<br>screw on. Disconnect hose at air pump,<br>connect. |
| Self-locking nuts (11) .....   | unscrew, screw on, replace.  |

Exhaust manifold ..... remove, insert.

**Note**

Clean sealing surface. Renew gaskets (closed metal surface faces cylinder head). Apply sealant A 001 989 25 20 in series of dots to new gasket to facilitate installation.

Leak test of all connection points ..... check with engine running.

**Notes**

Since July 1989 exhaust manifolds with modified shape have been installed to provide greater clearance for the air pump.

**Production breakpoint: July 1989**

| Model   | Engine  | Engine end no.<br>Manual transmission | Engine end no.<br>Automatic transmission |
|---------|---------|---------------------------------------|--|
| 124.051 | 104.980 | 000166                                | 000240                                   |
| 129.061 | 104.981 | 000065                                | 000459                                   |

Since September 1989 the flange for the ARF valve on RHD and LHD vehicles is identical.

**Production breakpoint: September 1989**

| Model   | Engine  | Engine end no.<br>Manual transmission | Engine end no.<br>Automatic transmission |
|---------|---------|---------------------------------------|--|
| 124.051 | 104.980 | 000558                                | 001708                                   |
| 129.061 | 104.981 | 000134                                | 000765                                   |

Since November 1990 collar nuts have been used for attaching the exhaust manifold to the cylinder head; previously nuts with washer.

**Production breakpoint: November 1990**

| Model                         | Engine  | Engine end no.<br>Manual transmission | Engine end no.<br>Automatic transmission |
|-------------------------------|---------|---------------------------------------|--|
| 124.031<br>124.051<br>124.091 | 104.980 | 004373                                | 018803                                   |
| 129.061                       | 104.981 | 000844                                | 008198                                   |

Since April 1991 the shield between exhaust manifold and air pump is of a sandwich design, previously pressing.

**Production breakpoint: April 1991**

| Model                         | Engine  | Engine end no.<br>Manual transmission | Engine end no.<br>Automatic transmission |
|-------------------------------|---------|---------------------------------------|--|
| 124.031<br>124.051<br>124.091 | 104.980 | 005972                                | 026409                                   |
| 129.061                       | 104.981 | 001181                                | 011225                                   |