

# 01-4400 Sealing air gallery in cylinder head

Preceding work:  
Camshaft removed (05-2200).

Operation no. of operation texts and work units or standard texts  
and flat rates

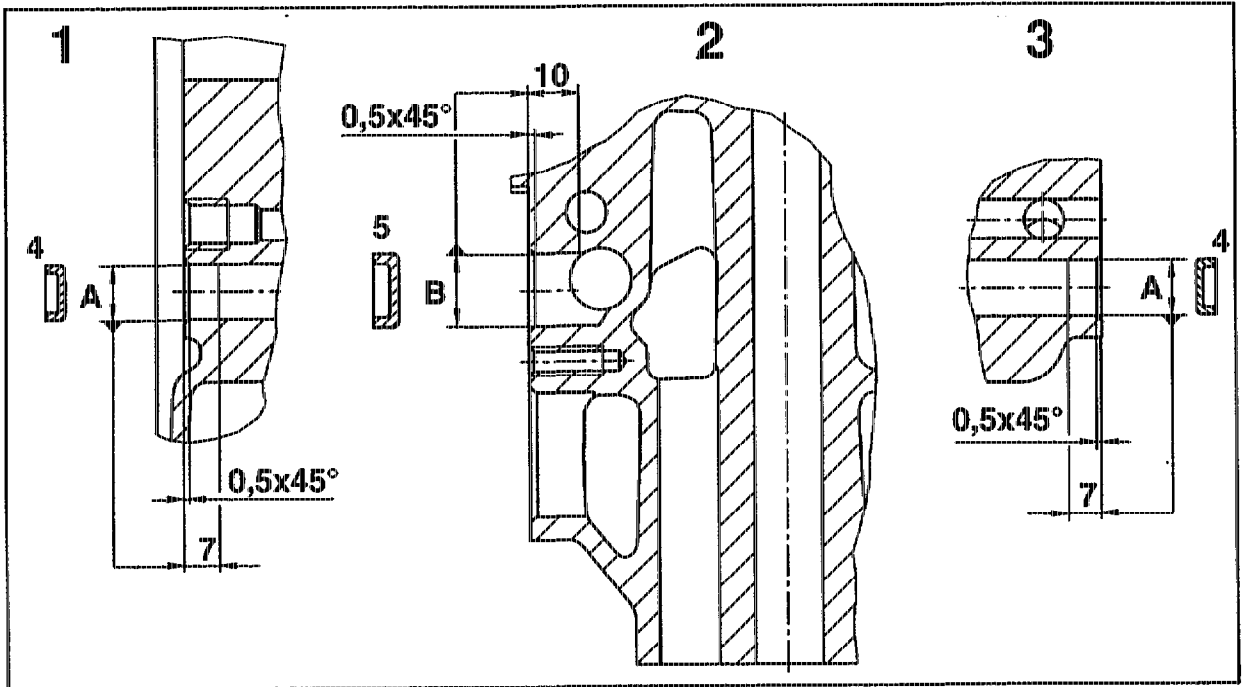

P01.30-0273-55

- A Longitudinal bore of air gallery in cylinder head
- B Air gallery connection to center exhaust side
- 1 Front of cylinder head

- 2 Center of cylinder head
- 3 Rear of cylinder head

Bore (A) in front of cylinder head (1) and  
in rear (3) .....  
New cap (4) part no. 000 443 012 001 .....

inspect for specified  $\varnothing$  of 12.00 to 12.04 mm.  
knock into bore (A).

**Note**  
If a cylinder head with secondary air injection  
gallery, connection bore (B), is used for an  
engine without secondary air injection, the  
connection bore (B) ( $\varnothing$  15.10 to 15.12) should  
be sealed with a cap (5) part no.  
104 016 00 33.