

01-4150 Removing and installing cylinder head

Operation no. of operation texts and work units or standard texts
and flat rates:
01-5800-5855

A. Models 124, 129 with engine 104.98

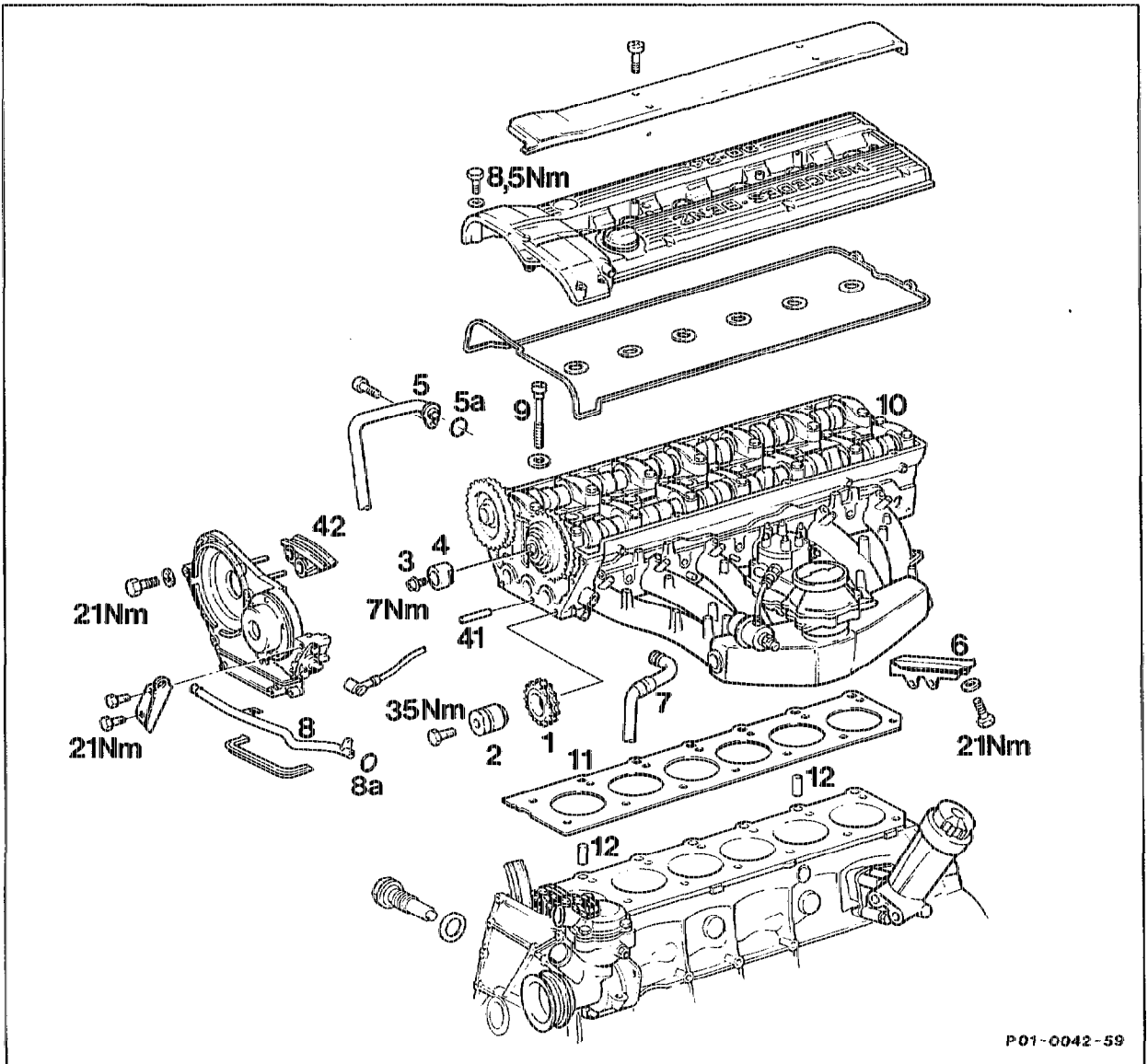

P01-0042-59

B. Model 140

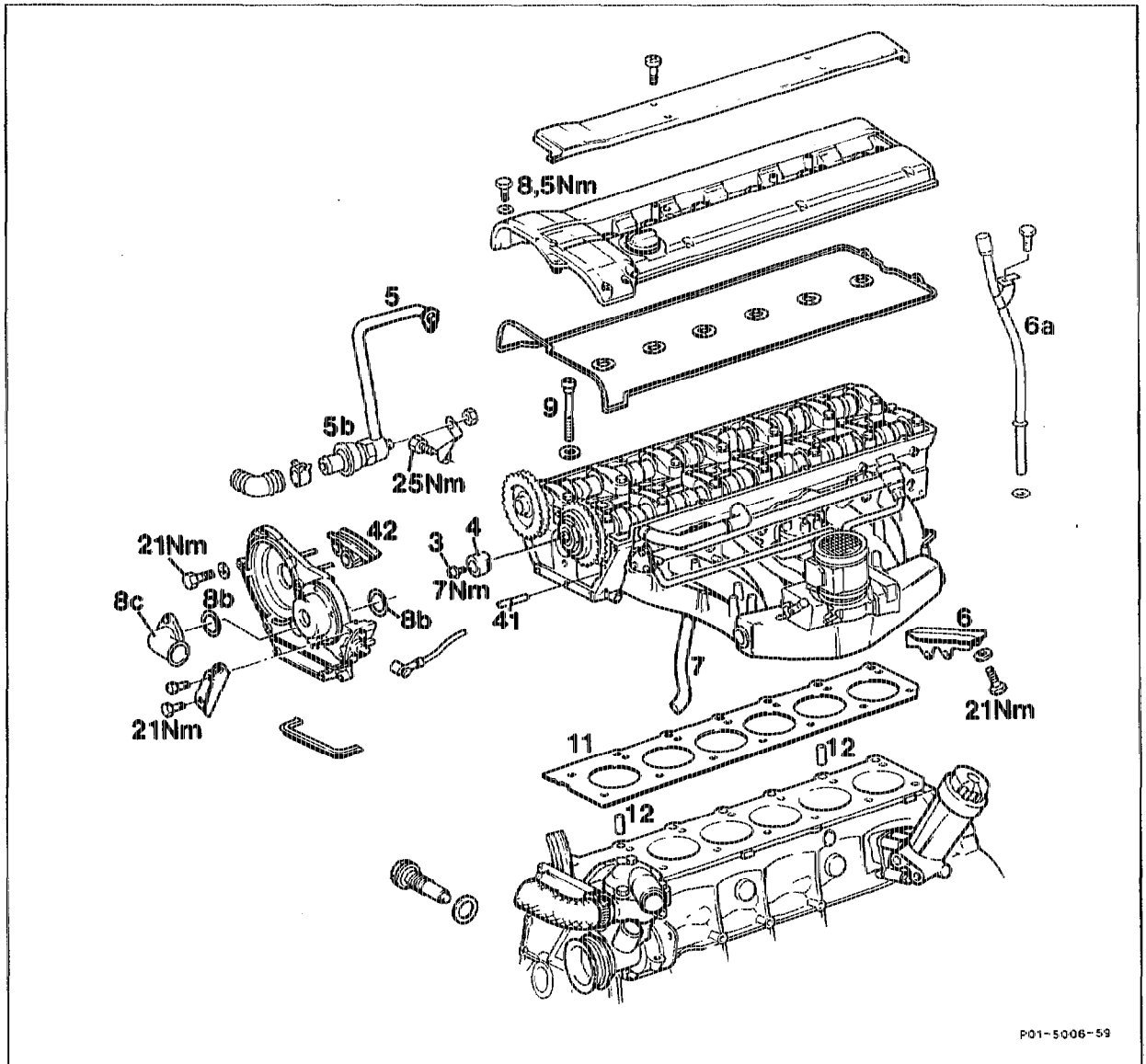

P01-5006-59

Ground cable at battery	disconnect, connect, encode radio, model 140 normalize power windows.
Coolant	drain, pour in (20-0100, step 1).
Piston of cylinder 1	position to ignition TDC (step 2).
Front cover at top	remove, install (01-2120).
Timing chain with camshaft sprocket	mark (step 4).
Pin (41) of guide rail	pull off, insert (step 5).
Engine 104.98:	remove guide sprocket (2) (left-hand thread), install (35 Nm, step 6).

Armature (3) at camshaft adjuster	remove, install.
Timing chain on camshaft sprockets	take off, fit on.
Cable of position sensor at right wheelhouse	take off, fit on (step 12).
Engine 104.98:	take off engine wiring harness, fit on (step 10).
Tempomat cruise control linkage	disconnect, connect.
Engine 104.99:	take off engine wiring harness, fit on (step 12).
Vacuum lines at intake manifold	take off, fit on (step 13).
Exhaust system at exhaust manifold	unbolt, bolt on.
Engine 104.98:	take off air injection pipe (5) at cylinder head, fit on (step 15), replace seal (5a).
Engine 104.99:	detach hose at non-return valve (5b) of air injection pipe, fit on (step 16).
Bracket of dipstick guide tube (6a) and intake manifold support (6)	unbolt, bolt on (step 17).
Line of crankcase air admission, combination support	take off, fit on (step 18).
Fuel filler cap (pressure)	open, close (step 19).
Engine 104.98:	disconnect fuel pipes at fuel distributor, connect (step 19).
Engine 104.99:	disconnect fuel pipes at left wheelhouse, connect (step 19).
If automatic transmission fitted:	unbolt dipstick guide tube at cylinder head, bolt on (step 20).
Bowden cable (accelerator control)	take off, fit on (step 21).
Control pressure cable	take off, fit on (step 23).
Coolant hoses and heating water return line (8) ..	take off, fit on (step 24). Not model 140.
Cylinder head bolts (9)	slacken (step 25).
Cylinder head (10)	take off together with intake manifold and exhaust manifold (step 26).
Cylinder head gasket (11)	replace (step 28).
	
The cylinder head gasket is not watertight until the engine has reached operating temperature, in other words, until a swelling operation has taken place. For this reason, the cooling system must not be pressure-tested until after the engine has reached operating temperature.	
Camshafts	position, secure (step 29).
Piston of cylinder 1	position to TDC (step 30).
Cylinder head bolts (9)	examine (01-4050).
Cylinder head (10)	install, tighten (steps 31, 33, 34).
Timing chain	fit on (step 35).

Tightening torques in Nm or tightening angle

Bolts for cylinder head cover	10
Bolts of camshaft bearing caps	21

1) Bolt head contact surface and thread oiled

Special tools

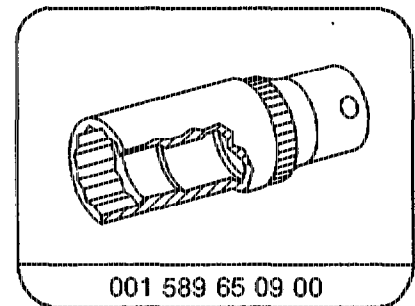
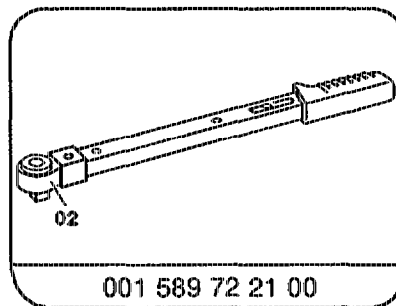
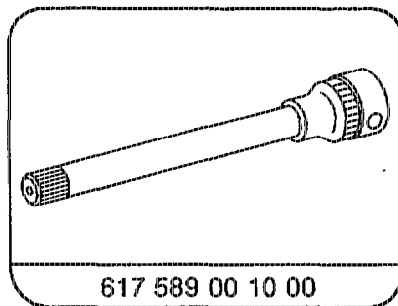
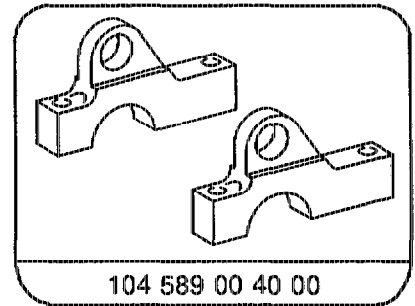
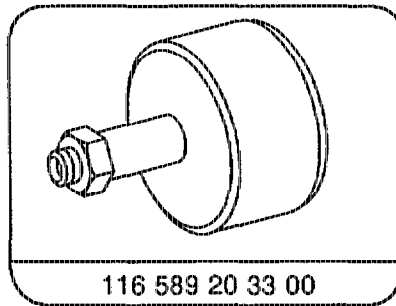
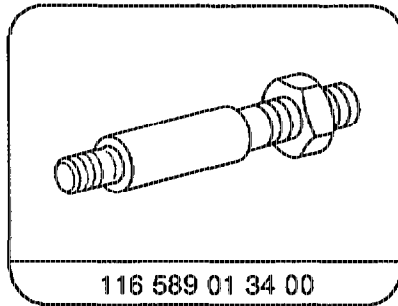

Note

Take off cylinder head together with camshafts, intake manifold and exhaust manifold once engine has cooled down.

Seal secondary air injection hole on side right at cylinder heads for engines without secondary air injection hole with end cover part no.

104 016 00 33.

Removing, installing

- 1 Drain coolant at crankcase (20-0100). Disconnect coolant and heating hoses at cylinder head.
- 2 Position piston of cylinder 1 to ignition TDC.
- 3 Remove front cover at top (01-2120).

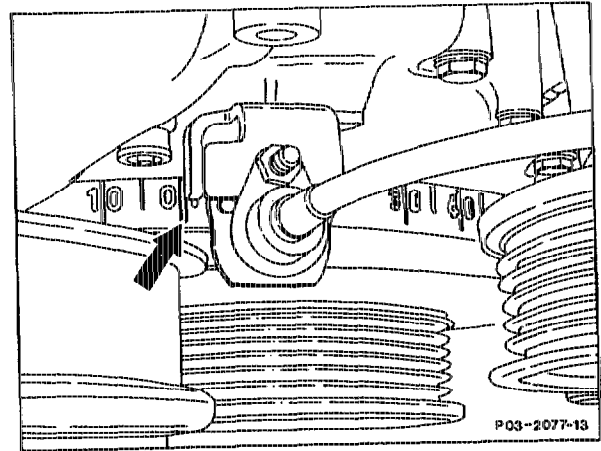

- 4 Mark position of camshaft sprockets to timing chain. To do this, apply coloured markings (arrows).

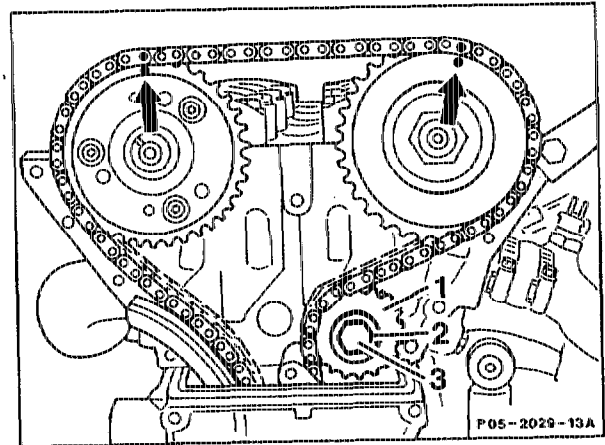

- 5 Pull off pin (1) for guide rail or friction rail with impact extractor 116 589 20 33 00 and threaded bolt 116 589 01 34 00.

Installation note

The thread in the pin (1) must be located at the front (in direction of travel) when installed.

Engine 104.98

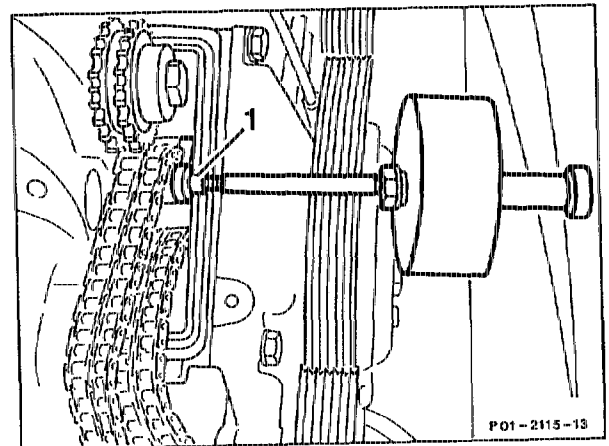

Engine 104.99

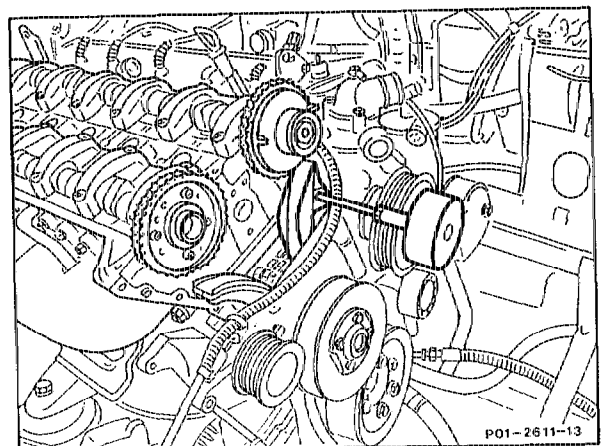

Engine 104.98

- 6 Unbolt guide sprocket (1) (left-hand thread) and take off together with bearing body (2).
- 7 Unbolt armature at camshaft adjuster.

Engine 104.98

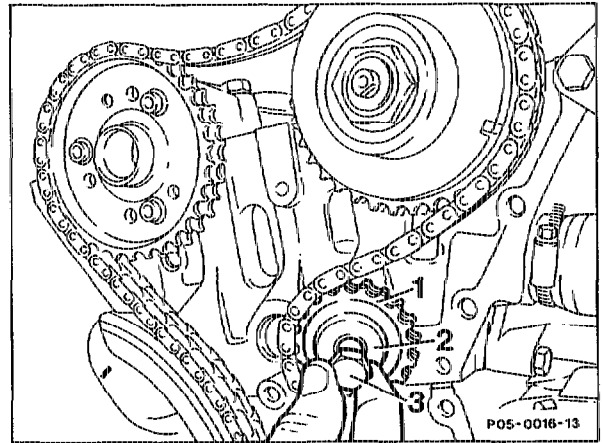

- 8 Take timing chain off camshaft sprockets.
- 9 Unplug position sensor at right wheelhouse.

Installation note

The connector must be plugged in watertight.

Engine 104.99

- 10 Take off engine wiring harness; to do this, slacken all the cable ties of the wiring harness and unplug all the connectors.
- 11 Disconnect cruise control linkage.

Engine 104.99

- 12 Unplug connector at engine separation point (X26/17).

Unplug connector of electronic accelerator actuator (M16/1x1), press ratchet (arrow), connector turns through 90° by means of a spiral spring.

Remove engine wiring harnesses from cable duct.

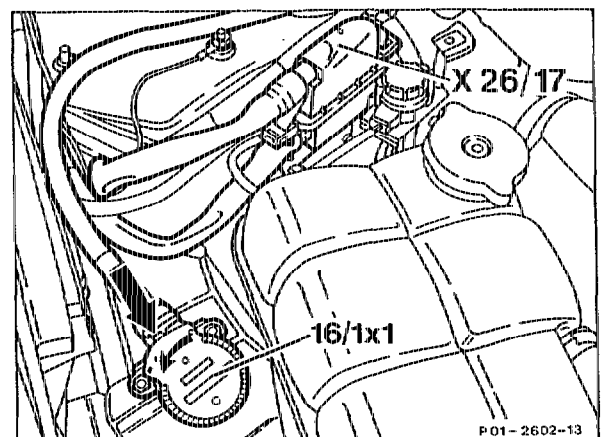

Model 140

13 Detach vacuum pipes at intake manifold (arrow), fit on.

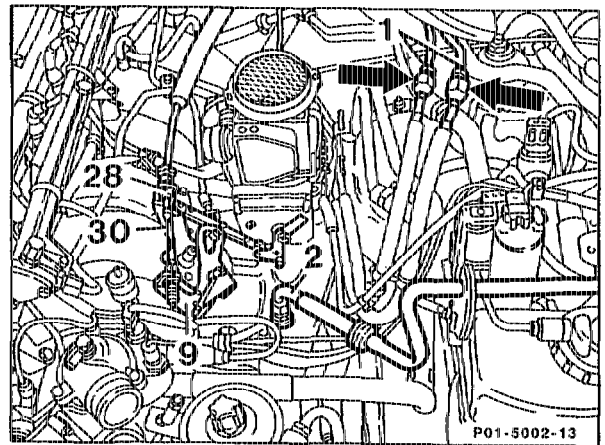

Engine 104.99

14 Unscrew bolts for exhaust system at flange of exhaust manifold.

15 Detach secondary air injection pipe (1) at the cylinder head, fit on. Replace seal.

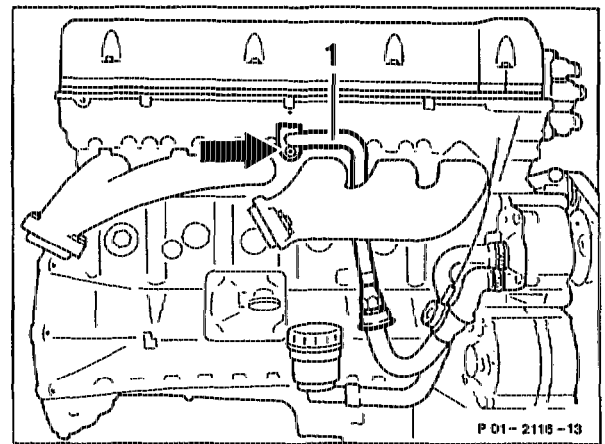

Engine 104.98

16 Detach hose at non-return valve of secondary air injection pipe (arrow), unbolt bracket (1).

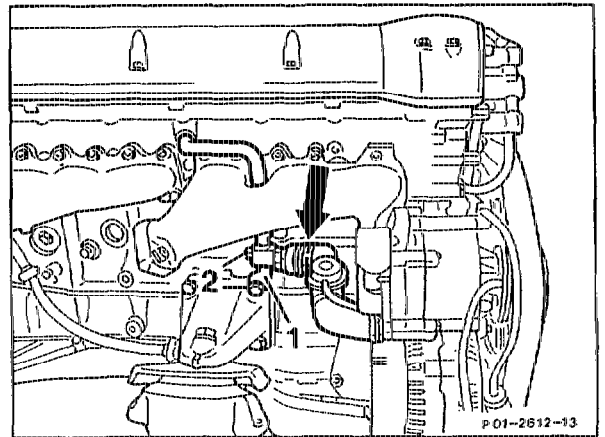

Engine 104.99

17 Unbolt bracket of dipstick guide tube and intake manifold support (arrows).

Note regarding model 140
Remove dipstick guide tube.

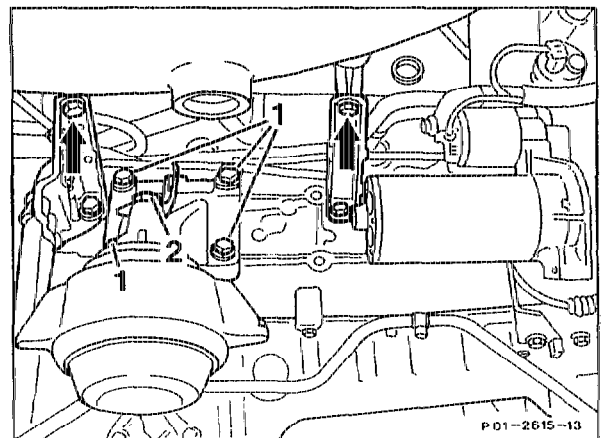

18 Detach pipe (43) of crankcase air admission at combination support (17).

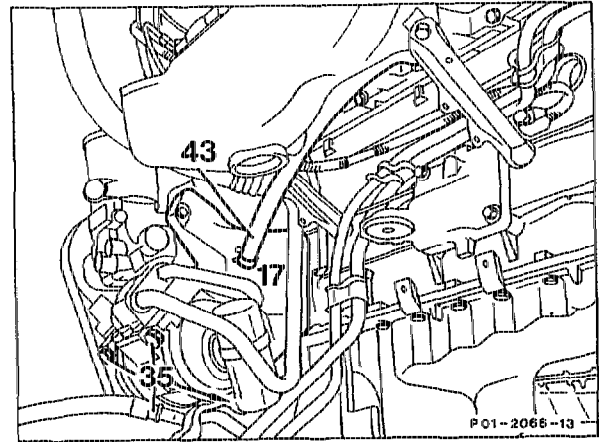

19 Briefly open fuel filler cap to release pressure in fuel tank. Unscrew fuel pipes (arrows). Counter-hold the connection fitting (1) when slackening the fuel pipe.

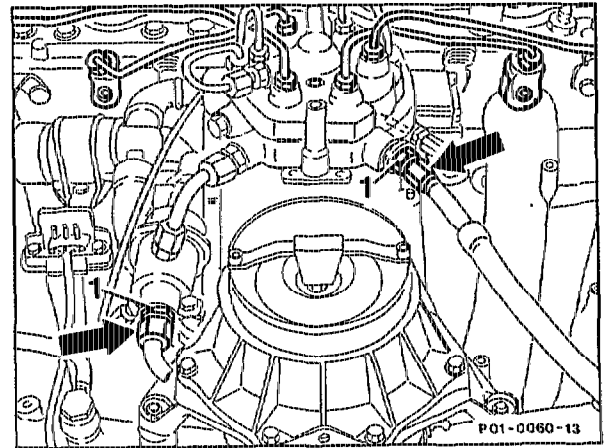

Models 124, 129
Engine 104.98

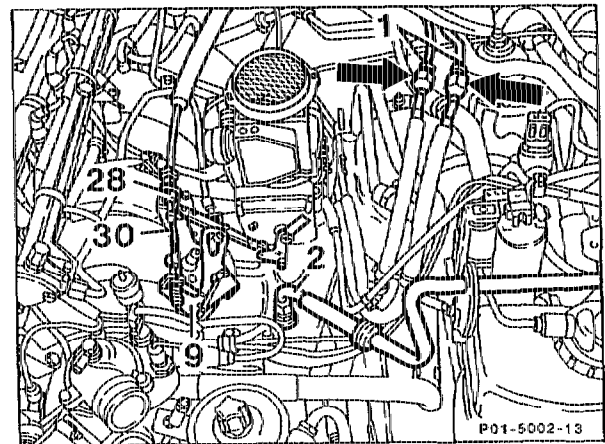

Engine 104.99

20 If automatic transmission fitted, unbolt dipstick guide tube at rear of cylinder head (arrow).

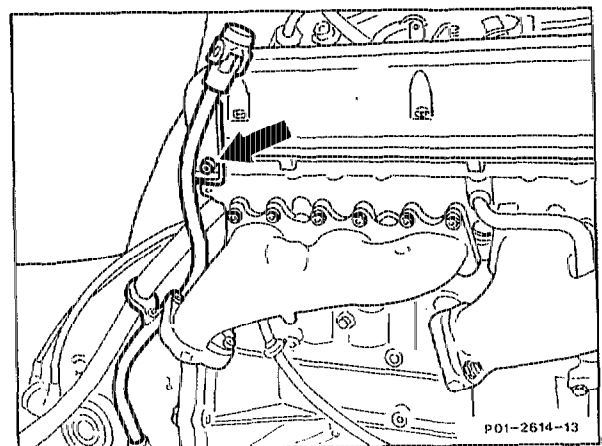

21 Detach Bowden cable (30) from the accelerator control lever (9). Compress plastic clip (28) and pull out Bowden cable.

Installation note

Adjust Bowden cable (30-1010).

22 Detach control pressure cable (4), compress plastic clip (5) and guide plastic clip with linkage through the bracket:

Engine 104.98

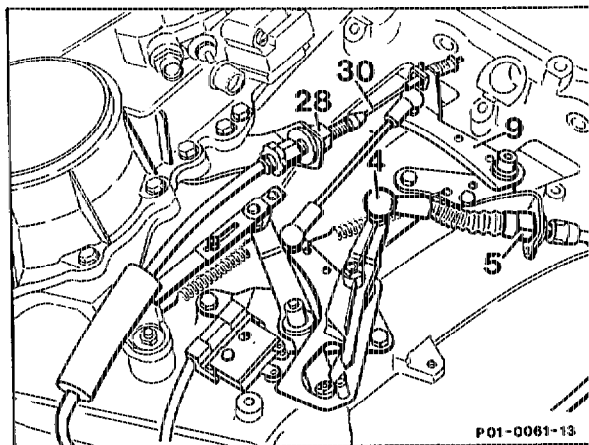

Engine 104.99

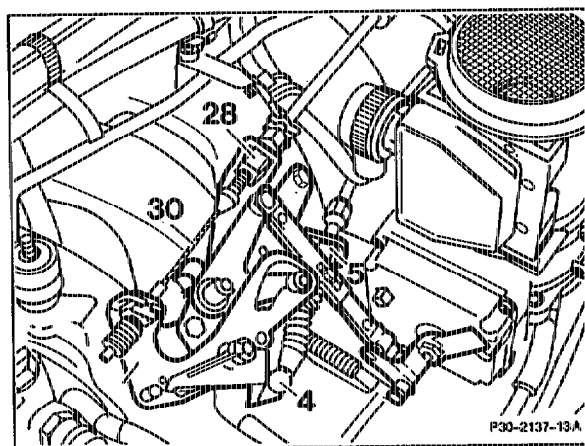

24 Slacken hose straps at the coolant hose to the coolant pump. Remove heating water return pipe.

25 When engine cold, slacken cylinder head bolts in stages in the reverse order of the tightening diagram, beginning with 14.

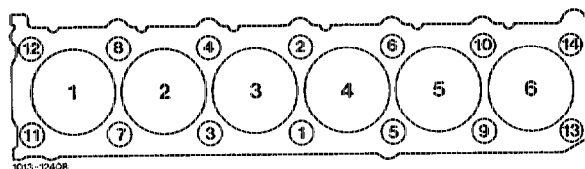

26 Remove camshaft bearing caps 9 and 13. Install lifting lugs, part no. 104 589 00 40 00. Lift off cylinder head with engine hoist and lifting tackle.

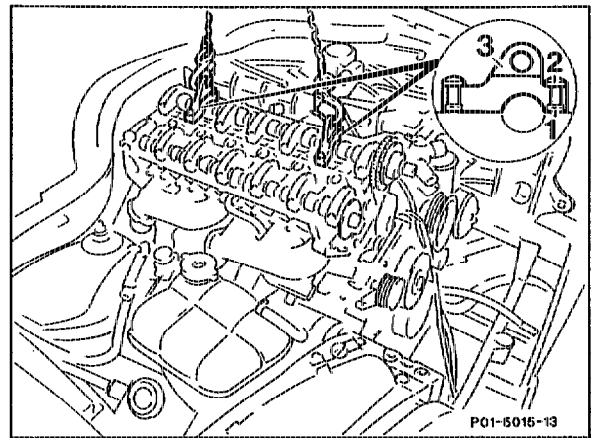

27 Clean contact surface on crankcase and on cylinder head.

Cylinder head identification	Engine 104.98	Engine 104.99
	104 016 16 20	104 016 17 20

28 Replace cylinder head gasket.



The cylinder head gasket is not watertight until the engine has reached operating temperature, in other words, until a swelling operation has taken place. For this reason, the cooling system must not be pressure-tested until after the engine has reached operating temperature.

b Identification part no.
c Identification recesses

Engine 104.98, 2 recesses
Engine 104.99, 3 recesses

Size D: Engine 104.98
90.2 mm + 0.5

Engine 104.99
90.9 mm + 0.5

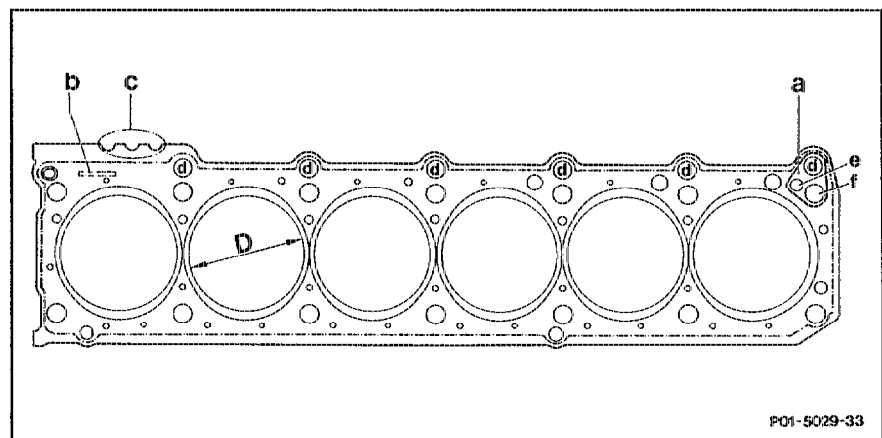

Installation note

Pay attention to dowel pins for locating cylinder head on crankcase.

29 Rotate camshafts so that bottom edge of holes in camshaft flange form a level with top edge of the cylinder head and check with 4 mm pins (1).

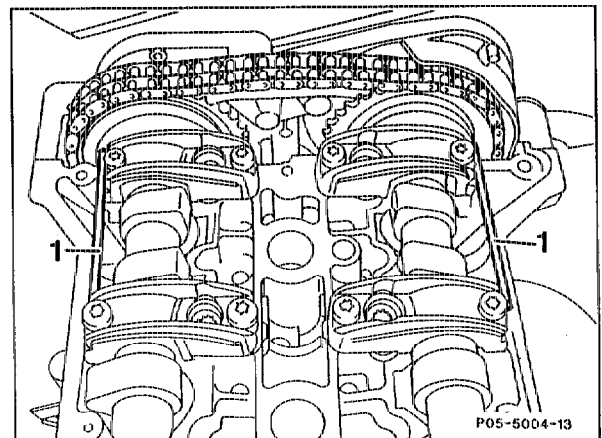

30 Check TDC position of piston in cylinder 1.

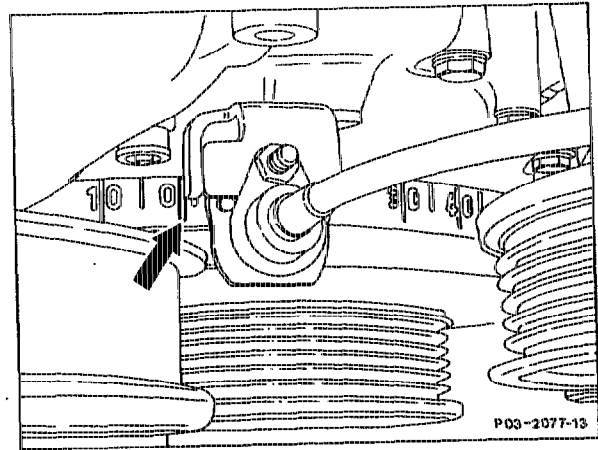

31 Fit on cylinder head with lifting tackle.

32 Examine cylinder head bolts (01-4050).

33 Oil the thread and the bolt head contact surface of the cylinder head bolts and insert.

34 Tighten cylinder head bolts in stages in the order of the tightening diagram, beginning with 1 (01-4050).

35 Fit on timing chain, pay attention to markings.

36 Remove pins from the camshaft flange.

37 Install in reverse order.

C. Models 202, 210

Preceding work:
 Front cover at top removed (01-2120).
 Resonance intake manifold top part removed
 (AR09.20-1310D).

Operation no. of operation texts and work units or standard texts
 and flat rates:
 01-5800

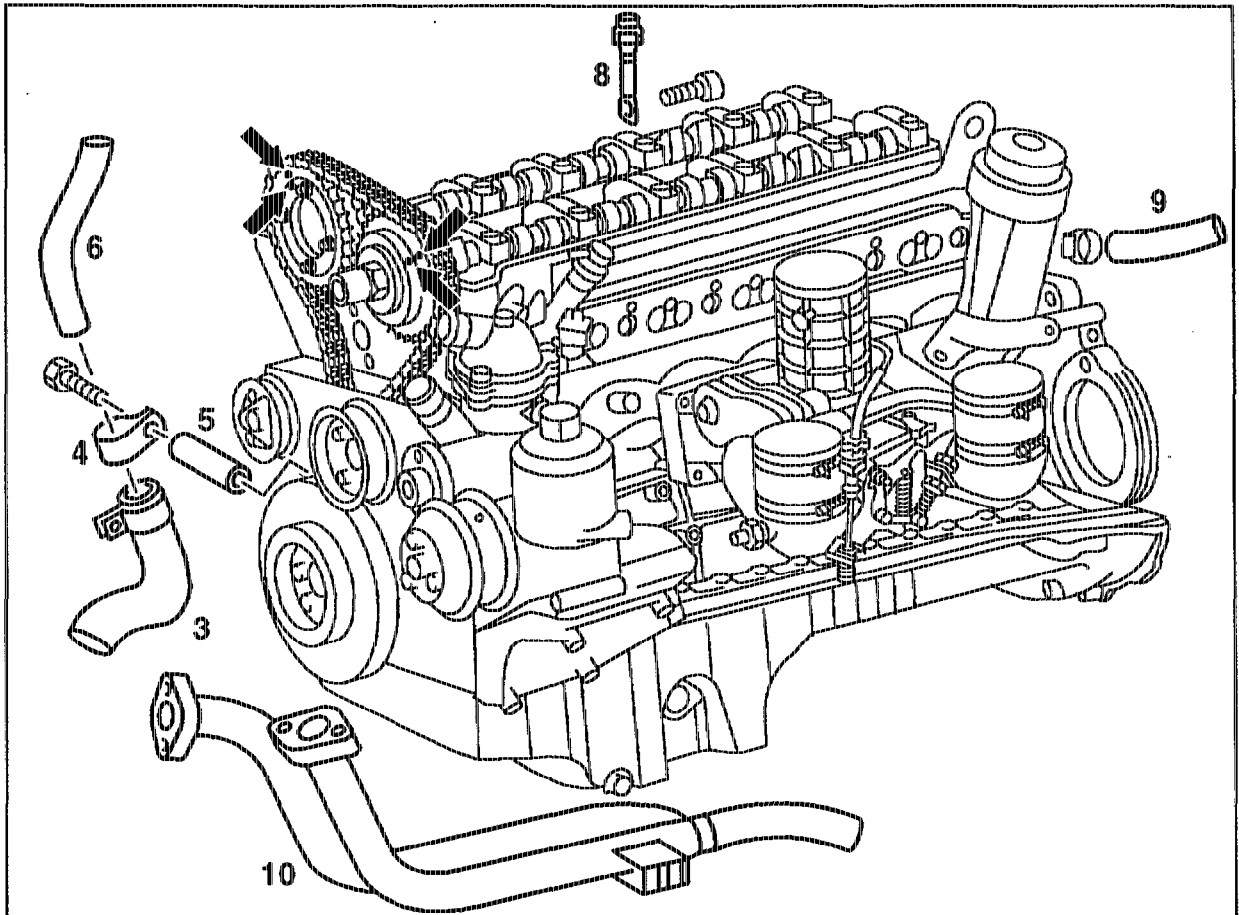

P01-5861-57

Front exhaust system (10)	unbolt at exhaust manifold, bolt on.
If secondary air injection fitted:	detach secondary air injection hose (3), fit on.
Bracket (4) with spacer sleeve (5) at secondary air injection pipe (6)	unbolt, bolt on.
Coolant at crankcase	drain (20-1142).
If automatic transmission fitted:	unbolt dipstick guide tube (8) at rear right of cylinder head, bolt on.
Coolant hose (9) at rear of cylinder head	take off, fit on.
Position of camshaft sprockets relative to timing chain	mark with coloured dots (arrows).

Note

Fit timing chain onto coloured markings
 (arrows).

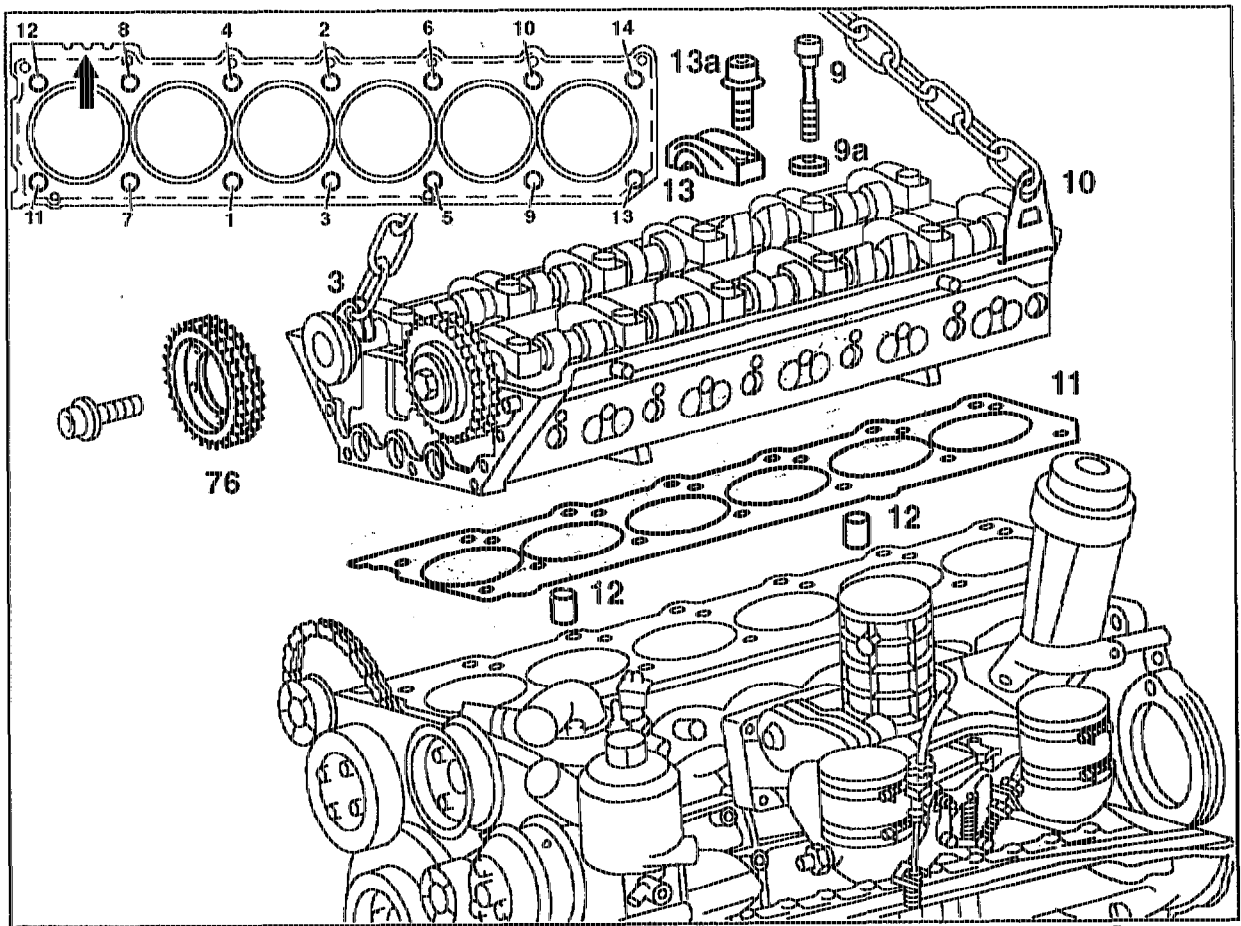

P01-5862-57

Exhaust camshaft sprocket (76)	unbolt, bolt on; tightening torques see (05-2180).
Timing chain of inlet camshaft sprocket	take off.
Cylinder head bolts (9) together with washers (9a)	slacken when engine cold with screwdriver bit 617 589 00 10 00 in stages in reverse order of tightening diagram, beginning with 14, unscrew.
First camshaft bearing cap (13) of exhaust camshaft	unbolt, bolt on (21 Nm).
Bracket (3) 104 589 00 40 00	install in place of first camshaft bearing cap (13) with bearing cap bolts (13a), bolt on (21 Nm).
Engine hoist	attach to bracket (3) and rear engine lifting point.
Cylinder head (10)	lift, remove.
Cylinder head contact surface	examine.

Tapped holes

clean.



Free of oil and water.

Cylinder head gasket (11)

replace.

Note

The cylinder head gasket (11) for engine 104.941 is identified with three recesses (arrows).



The cylinder head gasket is not watertight until the engine has reached operating temperature, in other words, until a swelling operation has taken place. For this reason, the cooling system must not be pressure-tested until after the engine has reached operating temperature.

Cylinder head (11)

install.

Dowel sleeves (12)

note.

Cylinder head bolts (9)

examine (01-4050).

Cylinder head bolts (9)

oil a thread and at bolt head contact surface.

Cylinder head bolts (9)

insert with washers (9a).

Cylinder head bolts

tighten in stages in order of tightening diagram, beginning with 1 (01-4050).

Special tools

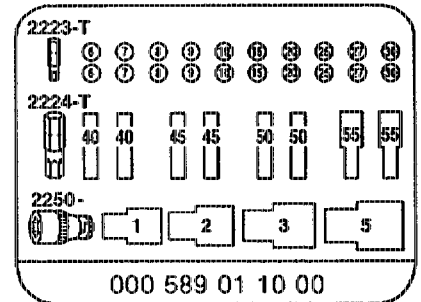
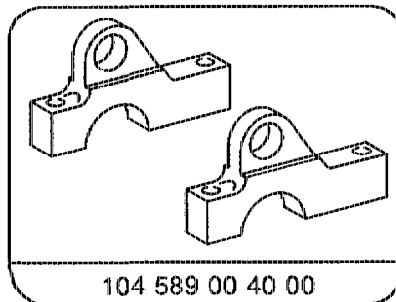
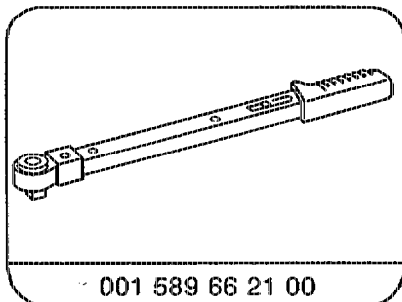

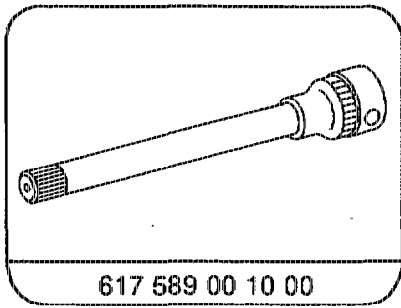

Tightening torques in Nm or tightening angle

Camshaft sprocket to camshaft Torx T40	see 05-2180
Bolts of camshaft bearing caps Torx T40	21

Note

Take off cylinder head together with camshafts, intake manifold and exhaust manifold once engine has cooled down.

Seal secondary air injection hole at right side on cylinder heads for engines without secondary air injection hole with end cover part no.

104 016 00 33.