

## 01-1220 Repairing threaded bores for cylinder head bolts

Preceding work:  
Cylinder head removed (01-4150).

Operation no. of operation texts and work units or standard texts  
and flat rates:

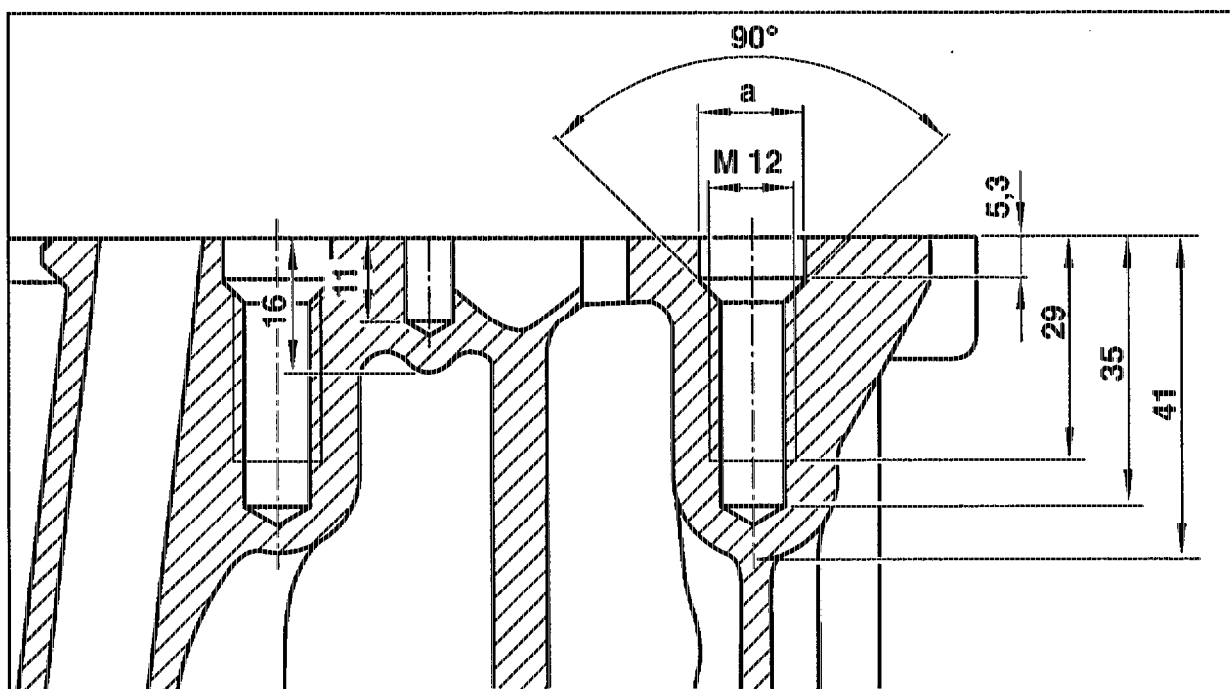

P01.40-0237-55

Bore ..... widen, pay attention to core plug depth.  
 HELI-COIL thread ..... tap.  
 HELI-COIL thread ..... screw in.

### Data in mm

|   |               |
|---|---------------|
| Ø size a  | 14.00 – 14.27 |
| Twist drill Ø                                   | 12.5          |
| Core hole depth from contact surface            | 35            |
| HELI-COIL threaded insert below contact surface | 5.3           |
| HELI-COIL thread length screwed in              | 26            |
| HELI-COIL thread length block size              | 23.1          |



### Commercially available tool

---

|   |  |
|---|--|
| HELI-COIL M12 hand thread tap for pre-tapping   | e. g. Böllhoff GmbH<br>Postfach 14 02 29<br>D-33622 Bielefeld<br>Order no. 0140 0120 104 |
| HELI-COIL M12 hand thread tap for final tapping | e. g. Böllhoff GmbH<br>Postfach 14 02 29<br>D-33622 Bielefeld<br>Order no. 0140 2120 102 |
| HELI-COIL M12 hand installation tool            | e. g. Böllhoff GmbH<br>Postfach 14 02 29<br>D-33622 Bielefeld<br>Order no. 0150 0112 300 |
| HELI-COIL M12 × 1.75 threaded insert            | e. g. Böllhoff GmbH<br>Postfach 14 02 29<br>D-33622 Bielefeld<br>Order no. 0130 0120 024 |

---

