

## 03-4640 Removing and installing needle bush in two-mass flywheel

Preceding work:  
Two-mass flywheel removed (03-4620).

Operation no. of operation texts and work units or standard texts  
and flat rates

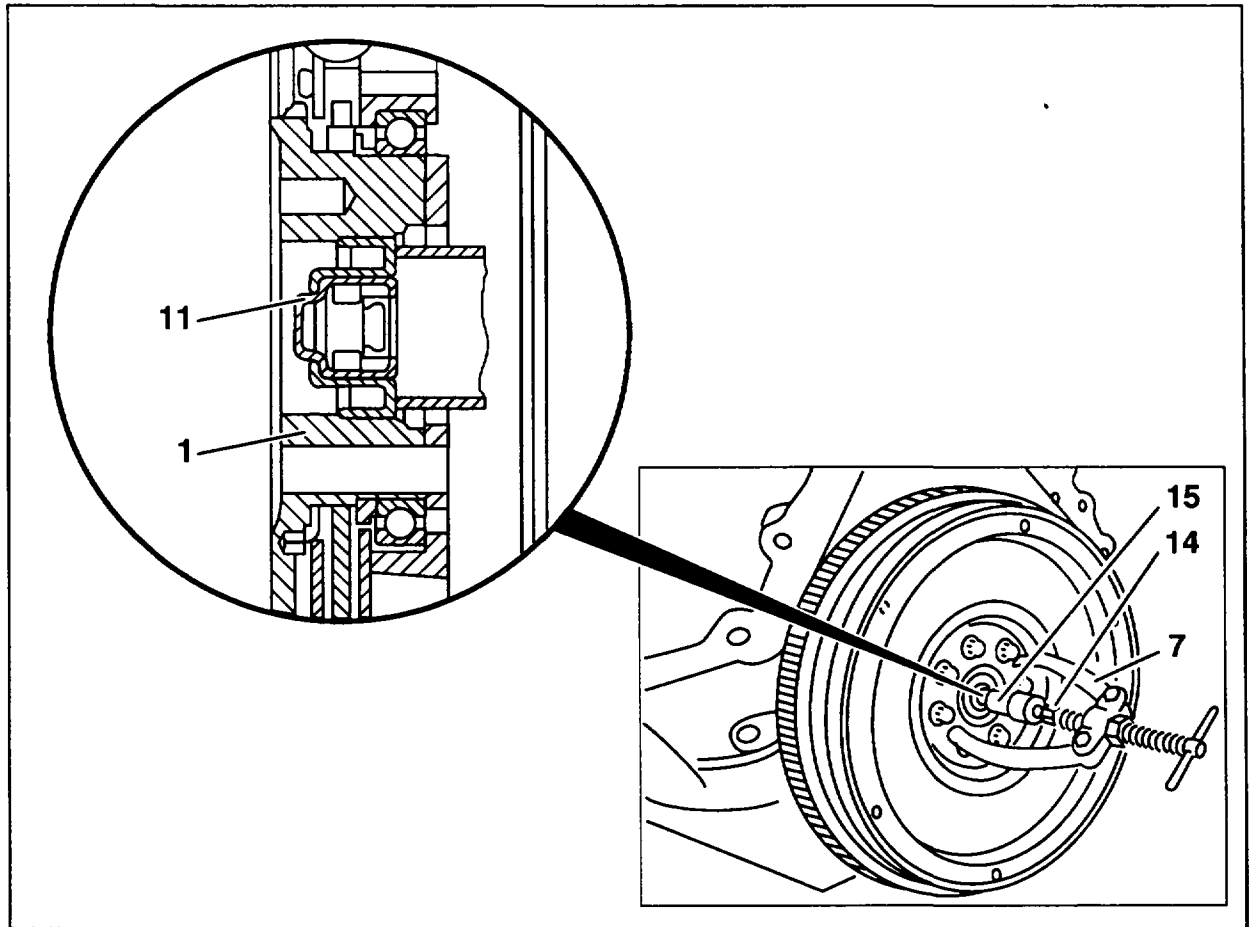

P03-5352-57

Puller (7) 000 589 33 33 00 with insert (15)	
000 529 25 33 00 (11) .....	place onto needle bush (11)
Nut (14) .....	turn, spread taper apart
Needle bush (11) .....	pull out

New needle bush (11) with  $\varnothing$  45 mm sleeve . . . . . press in at outer race as far as a stop



Press needle bush (11) in, do not knock in. Use  $\varnothing$  14.8 mm securing drift to prevent bearing rollers dropping out.

Needle bush (11) . . . . . check that it is tightly located at outer race in primary flywheel mass (1)

**Data in mm**

---

Mounting bore $\varnothing$ in two-mass flywheel	46.96 – 49.98
--	---------------

---

**Special tools**

